

**CITY OF GILLETT COMMON COUNCIL**  
**NOTICE OF REGULAR MEETING**  
Council Chambers – Municipal Building  
150 N McKenzie Ave – Gillett, WI 54124  
**THURSDAY, MARCH 6, 2025 AT 6:00 PM**  
**AGENDA**

Council may deviate from agenda as needed

1. Mayor calls meeting to order. Pledge of Allegiance
2. Clerk takes roll and informs the Council that the Open Meeting Law has been complied with
3. **Public Input**
4. Michael Kohn Veteran Banners
5. Discussion & possible action on February 6, 2025 Minutes
6. **Library Report:** Alderperson Drake
7. **Tourism & Marketing Commission/Gillett Area Chamber of Commerce:** Alderperson Luther
  - a. Discussion and Possible action on Circus
8. **Financial Report:** Clerk Treasurer
  - a. Updated Monthly Check Register Provided -February
9. **Police Department Report:** Police Chief Breitenbach
  - a. Discussion on Training, Public Relations, and Incident Summary Report
10. **Fire Department Report:** Fire Chief Hicks
  - a. Discussion on Training, Public Relations, and Incident Summary Report
11. **Health, Protection and License Committee Report:** Alderperson VanStraten
  - a. Discussion & possible action on 4<sup>th</sup> of July Celebration Picnic License and Operator License
  - b. Discussion & possible action on Life Insurance Policy
12. **Board of Public Works Committee Report:** Alderperson Drake
13. **Utility Committee Report:** Alderperson Young
  - a. Discussion & possible action on Water Line L&N Metal Works Easement
  - b. Discussion & possible action on private septic system application
  - c. Discussion & possible action on Water Tower Quotes
14. **Finance and Personnel Committee Report:** Alderperson Mohr
15. **Park and Cemetery Committee Report:** Alderperson Luther
  - a. Discussion & possible action on Resolution 1-2025 DNR Stewardship Outdoor Recreation Grant
  - b. Discussion & possible action on Update to City of Gillett CORP
  - c. Discussion & possible action on Request for amendment to the Oconto County CORP
  - d. Discussion & possible action on 4<sup>th</sup> of July Celebration Special Event Permit
16. **Planning Committee Report:** Alderperson Bunker
  - a. Discussion & possible action on 125 E Fourth Street New Home Build
17. **Clerk Treasurer's Report:** Clerk Treasurer
18. **Attorneys Report:** Conway, Olejniczak, and Jerry S.C. Attorneys at Law
19. **Public Input**
20. **Mayor's Report:** Mayor Blaskowski
21. **Adjourn**

Posted: City Hall and City Website----**Agenda subject to change up to 24 hours prior to meeting** Cc: City Council, Mayor, Attorney, Gillett Fire Dept., Gillett Police Dept. Contact City Clerk at 920-855-2255 prior to meeting if additional services are required. **It is possible that members of and possibly a quorum of members of the City Council or other committee may be in attendance** at the above stated meeting to gather information; no action will be taken by any governmental body at the above stated meeting other than the governmental body specifically referred to above in this notice.

**"An Equal Opportunity Employer"**

# CITY OF GILLETT COMMON COUNCIL

Council Chambers – Municipal Building  
150 N McKenzie Ave – Gillett, WI 54124

**THURSDAY, FEBRUARY 6, 2025 AT 6:00 PM**

## MINUTES

1. Council President Mohr called the meeting to order at 6:00 PM and the Pledge of Allegiance was recited.

### **Roll Call**

**Present:** Clerk Treasurer Chelsea Anderson, Alderpersons Nanette Mohr, Irene Drake, Jerry Luther, Ashley VanStraten, Matt Young, Utility Operator Matt Wickman, Public Works Foreman Nate Anderson, Fire Chief Kurt Hicks, Librarian Shannon Stoner and City Attorney Robert Gagan. Chamber of Commerce Chris Byars and MSA Engineer Dan Rammer. Mayor Jon Blaskowski, Alderperson David Bunker, and Police Chief Shane Breitenbach are excused.

2. **Clerk informs the Council that the Open Meeting Law has been complied with**

3. **Public Input:** Michael Kohn for Veteran Banners, place on next month agenda.

4. Discussion & possible action on minutes from January 2, 2025 Minutes

### **MOTION: Drake/VanStraten**

*Motion to approve minutes from January 2, 2025 Minutes*

**Voice Vote:** All Voting Aye - **MOTION CARRIED**

5. **Library Report:** Library Director Report- Library Director Report- February 2025

Programming:

We're having a whole week of programs the week of valentine's day including free blood pressure screenings from Gillett Prevea from 4-6, a Bad art Date/Family Night, and our winter market.

Project: Slime: Join The Children's Museum of Green Bay at Gillett Library Community Center on Wednesday, March 19 from 3:30-4:30 pm to learn about states of matter and make your slime.

Let's play away the winter blues with a Bluey Party at the Gillett Library Community Center on Thursday, March 27 from 11 am to 12 pm! Enjoy a Bluey-themed snack and activities! Build a robot to clean your room, play librarian, and shake those wiggles out with a game of Keepy Uppy!

Gillett Library will also host VITA this year. VITA provides free tax preparation.

Our Peep-le's Choice competition is back for another year! Make a book or library related diorama using peeps and our community will vote on the top two! Dioramas are due at the Gillett Public Library on April 1st. Voting will be from Monday, April 14 and voting will conclude on Thursday, April 17! Who will win the Peep-le's vote?

Newsletter and planning for summer 2025 is done.

I wrote two grants which I submitted to the ILS: The Library Services grant to increase our Large Print and digital collections and the Youth services grant to help pay for Summer Reading Program Performers.

6. **Tourism & Marketing Commission/Gillett Area Chamber of Commerce:** Alderperson Luther stated we discussed construction signage for the HWY 22 Project, ATV trail signage needs updating, and discussed marketing for the new playground. Getting a quote for a marketing/fundraising thermometer for the goals of our playground project. Chamber started a campaign on the 14<sup>th</sup> of February called Random Acts of Kindness.

7. **Financial Report:** Clerk Treasurer – Updated Monthly Check Register Provided

### **MOTION: Luther/VanStraten**

*Motion to approve January City and Utility Check Registers.*

**Voice Vote:** All Voting Aye - **MOTION CARRIED**

8. **Police Department Report:** Police Chief Breitenbach –Written Report

a. Discussion on Training, Public Relations, and Incident Summary Report

From the Chief's Desk; Gillett Police Department \ 188 incidents \ January 2025

Officer Hull has been doing extremely well adjusting to her new role as the Gillett School District Resource Officer. SRO Hull handled 35 law enforcement related events in the schools. Officer Hull also has provided several presentations on vaping, bullying, self-defense, and law enforcement's role in a school environment. Officer Hull continues to build her relationships with students and staff!

All the members of our department have completed their training in the proper use of our new LifeVac anti-choking devices. All the department members have completed their annual Blood Borne Pathogen training. Officers Anderson, Braun, and Kurtz also completed Responding to Utility Emergencies training hosted by WE Energies.

Oconto County Sheriff Todd Skarban informed me that the Gillett Police Department's ballistic shield has arrived, and we will be having shield use and application training in March.

The two new office desktop computers have arrived and have been installed. The new squad Toughbook computer is currently at Oconto County Technology Services having the required software uploads completed. These new computers should bring all of our computers up to date with the mandatory Windows 11 compatibility requirements.

**School Resource Officer Report: JANUARY 2025 Monthly Report**

For the month of January I responded to 35 law enforcement related calls between the secondary and elementary school. I also assisted with multiple student contacts.

I was able to recover 2 vapes from students on 6 calls

I had 3 contacts in regards to welfare checks outside of the school hours at student residences. I had 1 student that I had 2 EM1 calls.

I attended multiple basketball games with no incidents at the games

I gave a presentation/answered questions about vaping, bullying, self-defense, & citations

I have been building relationships with the students and teachers in both schools. Students are aware they can come to me with issues and concerns. I have had multiple elementary school students that had spoke with me about home life and things law enforcement could do to make them feel safe. I have noticed multiple parents that have had negative contacts with the school now work on building relationships with staff to assist their child.

I attended multiple meetings in regards to one student that we had 7 calls with in the month of January. Arrangements were made to assist the student with class schedule and now the student is thriving.

We have had multiple THC calls so a k9 search is being set up to assist the school and determine where and how we can assist students and make the school a safe place for all.

All citations that have been issued so far this month have been for truancy issues.

9. **Fire Department Report:** Fire Chief Hicks

a. Discussion on Training, Public Relations, and Incident Summary Report: January Calls:

Jan 3 Gas leak Underhill Auto Aid, Jan 4 Structure Fire Oconto Falls MABAS, Jan 4 Electrical Fire A&W, Jan 8 Alarm at Serenity Gardens, Jan 12 Auto Accident, Jan 21 Gas Leak, Jan 30 Structure Fire Underhill, Jan 30 Grass Fire Oconto Falls, Grass Fire Underhill.

Training: Once a month, we have our in house training, and we work on basic concepts like search and rescue and working with breathing apparatuses. The City Fire Department is trying to progress on a program of implementing a class for young people that co-ops with the technical college to give credits towards Fire Fighter or EMS degrees. Its called the Youth Apprenticeship Program, where young individuals can explore programs of interest to them, take related courses, learn in classroom, and take to a career. We will apply for a grant to help will costs. We have 14 year olds joining the Fire Department, they cannot go on fire calls, but they can train, learn, and earn certifications before they turn 18.

10. **Health, Protection and License Committee Report:** Alderperson VanStraten

- a. Discussion and Possible Action on Roy Hubbard Memorial Truck Show Picnic License

**MOTION: Drake/Luther**

*Motion to approve the Roy Hubbard Memorial Truck Show Picnic License.*

**Voice Vote:** All Voting Aye - **MOTION CARRIED**

- b. Discussion and Possible Action on Oconto County Youth Fair Picnic License

**MOTION: Drake/Young**

*Motion to approve the Oconto County Youth Fair Picnic License August 20-24, 2025.*

**Voice Vote:** All Voting Aye - **MOTION CARRIED**

- c. Discussion and Possible Action on Operator License for Abigail Gutenberger

**MOTION: Luther/VanStraten**

*Motion to approve an Operator License for Abigail Gutenberger.*

**Voice Vote:** All Voting Aye - **MOTION CARRIED**

11. **Board of Public Works Committee Report:** Public Works Foreman Nate Anderson stated Christmas lights are down, cleaned chipper and sharpened knives, new hydraulic pump on salter, washed and cleaned vehicles, plowed and salted, stained pine wood in Clerks Office, and took down a small file room from Clerks Office files. We made a new storage area with upgraded shelving and organized by year that takes up less parking space in the Public Works garage.

12. **Utility Committee Report:** Utility Operator Matt Wickman stated REL (Robert E. Lee) was here and went through the Water and Sewer Highway 22 project with him, there were very few changes, they are almost done with plans. Got quotes for painting the inside of water tower, which has to be done every five years, about \$40,000; we have to replace the mixer, and add vent to bring to code. Ron Anderson retired; his last day was February 3, 2025. Everyone thanked him for his 20 years of service and said he would be greatly missed.

- a. Discussion and Possible Action on interim financing from Peshtigo National Bank

**MOTION: Drake/Young**

*Motion to approve interim financing at 4.65 percent for 15 months at Peshtigo National Bank, a 4-million-dollar loan for Highway 22 Project.*

**Roll Call Vote:** All Voting Aye - **MOTION CARRIED**

- b. Discussion and Possible Action on MSA Contract for a Licensed Utility Operator – With Ron Anderson retiring, the City of Gillett is required to have a Licensed Utility Operator on Site. MSA can provide that until we meet the requirements.

**MOTION: Luther/Drake**

*Motion to approve the MSA Contract for a Licensed Utility Operator at \$4,800 dollars a month.*

**Roll Call Vote:** All Voting Aye - **MOTION CARRIED**

13. **Finance and Personnel Committee Report:** Alderperson Mohr- Went through the City and Utility Check Registers before Council.

**14. Park and Cemetery Committee Report:** Alderson Luther

- a. Discussion and Possible Action on Zippel Park CDBG Grant Application and Zippel Park Engineering Agreement

**MOTION: Luther/Drake**

*Motion to approve applying for the CDBG Grant Application for \$15,000 covers up to 50% of playground and 80% of walking trails. 1-million-dollar grant 2/3 grant 1/3 local grant. CDBG needs 100% design done to apply.*

**Roll Call Vote:** All Voting Aye - **MOTION CARRIED**

**MOTION: Luther/Drake**

*Motion to approve the \$55,000 Engineering Agreement and Stewardship Grant.*

**Roll Call Vote:** All Voting Aye - **MOTION CARRIED**

- b. Discussion and Possible Action on Special Events Roy Hubbard June 13-14 and Oconto County Fair August 20-24, 2025

**MOTION: Drake/VanStraten**

*Motion to approve Special Events Roy Hubbard June 13-14 and Oconto County Fair August 20-24, 2025*

**Roll Call Vote:** All Voting Aye - **MOTION CARRIED**

**15. Planning Committee Report:**

- a. Discussion and Possible Action on new home build and change of address to 100 N Richmond Avenue

**MOTION: Drake/Luther**

*Motion to approve Kathy Campshure's new home build with a variance and change of address to 100 North Richmond Avenue, build to meet all state and federal DNR contamination requirements.*

**Voice Vote:** All Voting Aye - **MOTION CARRIED**

16. **Clerk Treasurer's Report:** Clerk Treasurer - Clerk Anderson stated all annual invoices have been sent out, such as yearly Municipal Court Fee, ATV Trail Sponsor Fees, and Non-Profit Garbage/Recycling Pick Up Fees. Kerber Rose has completed W-2s and 1099s and I have mailed those out. Tax Collection has concluded. I have completed our OSHA Injury and Illness Reporting. We have an Election on Tuesday, February 18, 2025 for State Superintendent of Public Instruction. Please come vote.

17. **Attorneys Report:** Conway, Olejniczak, and Jerry S.C. Attorneys at Law- City Attorney Robert Gagan- still ongoing parking issues Waters Edge on Armstong, they will assign spots, will repair parking lot in spring, and will look into buying additional parking space. Working on easements for storm water for the lot L&N Metal Works is taking over. Also had to do bank legal opinions for the interim loan we are taking out from Peshtigo National Bank.

18. **Public Input:** None

19. **Mayor's Report:** No Report

20. **Adjourn** at 7: 10 PM

**MOTION: Drake/VanStraten**

*Motion to adjourn.*

**Voice Vote:** All Voting Aye - **MOTION CARRIED**

Respectfully Submitted,  
Clerk Treasurer Chelsea Anderson



## Library Director Report

March 2025

### 1. Programming

1. Thursday, March 13 from 5-7 pm is our Winter Market.
2. Project: Slime: Join The Children's Museum of Green Bay at Gillett Library Community Center on **Wednesday, March 19 from 3:30-4:30 pm** to learn about states of matter and make your slime.
3. Money as you Grow Storytime on **Tuesday, March 25 at 10:30 am**. Each family receives a book (Berenstein Bears "Trouble with Money") parent guide, craft, and learning activities about money
4. Let's play away the winter blues with a Bluey Party at the **Gillett Library Community Center on Thursday, March 27 from 11 am to 12 pm!** Enjoy a Bluey-themed snack and activities! Build a robot to clean your room, play librarian, and shake those wiggles out with a game of Keepy Uppy! Gillett Library will also host VITA this year. VITA provides free tax preparation.

5. Our Peep-le's Choice competition is back for another year! Make a book or library related diorama using peeps and our community will vote on the top two! **Dioramas are due at the Gillett Public Library on April 1st. Voting will be from Monday, April 14 and voting will conclude on Thursday, April 17!** Who will win the Peep-le's vote?

6.

2. I wrote a grant for the Teen Inclusive Internship. It is a \$2,500 grant to grants for up to seven Wisconsin Libraries to fund library internships for local high school juniors or seniors to be completed between June 1st, 2025, and August 31st, 2025. It offers a paid mentor internship for local high school juniors or seniors to experience the world of librarianship.
3. I attended Bystander and Anti-human Trafficking Training at NWTC in February. The training is meant to train library staff ahead of the 2025 NFL Draft in Green Bay. Training topics included gaining a deeper understanding of human trafficking and the role libraries can play in identifying, responding to, and supporting victims. We will also learn about ways that we can build community awareness and provide education to help with prevention as well as conflict intervention tactics.
4. We started a job binder for local jobs. Patrons who are looking for jobs can peruse the binder to see what is available locally.

## CITY

Check Nb	Check Date	Vendor name	Check Amount	Transaction memo
	WR 02/28/2025	WISCONSIN DEPARTMENT OF ETF- W	10,914.65	January 2025 WRS Remittance
22625	02/26/2025	WISCONSIN DEPARTMENT OF JUSTIC 7		BACKGROUND CHECK
39704	02/04/2025	ANDERSON, RONALD	1,290.30	Pay period 01/27/2025 to 02/0
39705	02/04/2025	ASTREA	536.75	PD TRANSFER PLUS PHONE PI
39706	02/04/2025	MCCLONE	2,320.53	INVOICE#12983
39707	02/04/2025	OCONTO COUNTY CLERK	118.5	2025 DOG TAX SETTLEMENT
39708	02/04/2025	OCONTO COUNTY TREASURER JAIL A 100		Jan-25
39709	02/04/2025	STATE OF WISCONSIN COURT FINES	346.4	CITY OF GILLETT JANUARY 20
39710	02/04/2025	THE FLOWER SHOPPE	84.4	JAMES HENKEL- FUNERAL
39711	02/04/2025	ANDERSON, RONALD	8,635.38	Pay period 01/27/2025 to 02/0
39712	02/13/2025	BUMPER TO BUMPER	13.79	
39713	02/13/2025	BUSINESS CARD	120.86	ROOF PATCH KIT
39714	02/13/2025	BUSINESS CARD	717.45	POST OFFICE
39715	02/13/2025	BUSINESS CARD	147.87	-POWER STRIP
39716	02/13/2025	CONWAY, OLEJNICZAK & JERRY, S.C.	4,353.50	STATEMENT#50876
39717	02/13/2025	CULLIGAN OF OCONTO COUNTY	13	ACCOUNT#1055791
39718	02/13/2025	GARROW OIL MARKETING, INC	201.02	
39719	02/13/2025	GFC LEASING - WI GORDON FLESCH (	115.21	
39720	02/13/2025	GILLETT HARDWARE	377.48	
39721	02/13/2025	GILLETT SCHOOL DISTRICT	191,444.30	FEB SETTLEMENT
39722	02/13/2025	KERBER ROSE	5,650.00	SERVICES FOR 01/31/25
39723	02/13/2025	LED ILLUMINATION SPECIALISTS LLC	450	
39724	02/13/2025	NORTHEAST WI TECHNICAL COLLEGE	18,185.17	FEB SETTLEMENT - CITY OF G
39725	02/13/2025	OCONTO COUNTY HIGHWAY DEPART	501.68	206 BRIDGE INSPECTION
39726	02/13/2025	OCONTO COUNTY LUMBER INC	183.8	LUMBER FOR SHELVING
39727	02/13/2025	OCONTO COUNTY TREASURER	97,385.12	FEB SETTLEMENT - TAXES
39728	02/13/2025	OCONTO ELECTRIC	10.23	KLAUS LAKE & PARK LIGHT, C
39729	02/13/2025	SECURIAN FINANCIAL GROUP INC	110.28	Mar-25
39730	02/13/2025	SECURIAN FINANCIAL GROUP INC	15.78	Feb-24
39732	02/18/2025	BUSINESS CARD	303.79	HOSE REELS
39733	02/18/2025	CENTURY LINK	50	ACCT#301617494
39734	02/18/2025	WOLF RIVER PERFORMING ARTS	85	FULL PAGE AD
39735	02/19/2025	GILLETT SCHOOL DISTRICT	105.69	Feb-25
39736	02/19/2025	GRAINGER	36.93	
39737	02/19/2025	MSA PROFESSIONAL SERVICES INC	3,251.34	2023 INCOME SURVEY AND C
39738	02/19/2025	OCONTO COUNTY TREASURER	18.84	FEB SETTLEMENT - TAXES
39739	02/19/2025	RIESTERER & SCHNELL, INC	487.92	
39740	02/26/2025	AMERICAN LEGAL SERVICES	36.2	GILLETT POLICE DEDUCTION
39741	02/26/2025	FINNEGAN LAKE WALLEYE CLUB	50	DEPOSIT REFUND
39742	02/26/2025	GFC LEASING - WI GORDON FLESCH (	33.22	
39743	02/26/2025	GRAINGER	110.49	INV#9414034844
39744	02/26/2025	OCONTO COUNTY TECHNOLOGY SER'972		SPILLMAN MOU 2024



39745	02/26/2025	QUILL CORPORATION	34.99	INVOICE#42735314
39746	02/26/2025	R&R ASSESSING SERVICES	770	CITY ASSESSOR
39747	02/26/2025	SBX,LLC.	183	INVOICE#4060
39748	02/26/2025	TELFORD EQUIPMENT CONSULTING	7,750.21	INV#2203-809 & 2203-810
39749	02/26/2025	WE ENERGIES	153.97	INVOICE#5373992075
39750	02/26/2025	WE ENERGIES	6,215.28	
39751	02/26/2025	WISCONSIN SUPREME COURT-MUNIC 800		CONTINUAL JUDICIAL EDUCATION
39752	02/26/2025	BUSINESS CARD	262	SQUAD WASHED
39753	02/26/2025	MARCO TECHNOLOGIES LLC.	48.74	INV13445767
39754	02/26/2025	WISCONSIN DEPARTMENT OF JUSTICE	218.25	455TIME-0000017573
39755	02/27/2025	24/7 WELL AND PUMP SERVICE	829.23	24/7 WELL AND PUMP SERVICE
39756	02/27/2025	AT&T MOBILITY	315.66	POLICE
39757	02/27/2025	BURKE TRUCK AND EQUIPMENT INC	2,134.02	INV#2025/00376
39758	02/27/2025	GFL ENVIRONMENTAL	13,069.94	INV#U60000260649
39759	02/27/2025	OCONTO COUNTY LUMBER INC	85.49	
39760	02/27/2025	OCONTO COUNTY TREASURER JAIL A 100		Feb-25
39761	02/27/2025	OLD DOMINION BRUSH	723.22	INV#9063809-STREET SWEEP
39762	02/27/2025	PESHTIGO NATIONAL BANK	15,130.00	PRINCIPAL WASHINGTON STATE
39763	02/27/2025	POWERHOUSE RETAIL SERVICES LLC 300		PD 2X FROM 3RD PARTY-NEED
39764	02/27/2025	STATE OF WISCONSIN COURT FINES	460.8	CITY OF GILLETT FEBRUARY 2025
	EFTP 02/05/2025	INTERNAL REVENUE SERVICE -EFTPS	4,342.94	Payroll Withholding 2.4.25
	EFTP 02/13/2025	INTERNAL REVENUE SERVICE -EFTPS	5,244.94	Payroll Withholding 2.13.25
	EFTP 02/27/2025	INTERNAL REVENUE SERVICE -EFTPS	4,846.98	Payroll Withholding 2.27.25
V639	02/13/2025	AMMERMAN, ANN	426.15	Pay period 01/27/2025 to 02/02/2025
V639	02/13/2025	AMMERMAN, THOMAS	267.81	Pay period 01/27/2025 to 02/02/2025
V639	02/13/2025	ANDERSON, CHELSEA	1,496.49	Pay period 01/27/2025 to 02/02/2025
V639	02/13/2025	ANDERSON, ERIC	821.67	Pay period 01/27/2025 to 02/02/2025
V639	02/13/2025	ANDERSON, LISA	669.62	Pay period 01/27/2025 to 02/02/2025
V639	02/13/2025	ANDERSON, NATHAN	1,774.00	Pay period 01/27/2025 to 02/02/2025
V639	02/13/2025	BLASKOWSKI, JONATHAN	461.75	Pay period 02/01/2025 to 02/02/2025
V640	02/13/2025	BRAUN, ALLISON	712.51	Pay period 01/27/2025 to 02/02/2025
V640	02/13/2025	BREITENBACH, SHANE	2,131.93	Pay period 01/27/2025 to 02/02/2025
V640	02/13/2025	BUNKER, DAVID	277.05	Pay period 02/01/2025 to 02/02/2025
V640	02/13/2025	DRAKE, IRENE	277.05	Pay period 02/01/2025 to 02/02/2025
V640	02/13/2025	GABLE, RUSSELL	1,755.25	Pay period 01/27/2025 to 02/02/2025
V640	02/13/2025	GRZYWACZ, CHRISTY	476.33	Pay period 01/27/2025 to 02/02/2025
V640	02/13/2025	HULL, ASHLEY N	1,871.31	Pay period 01/27/2025 to 02/02/2025
V640	02/13/2025	KURTZ, KATELYN	321.15	Pay period 01/27/2025 to 02/02/2025
V640	02/13/2025	LUTHER, JEROME	277.05	Pay period 02/01/2025 to 02/02/2025
V640	02/13/2025	MOHR, NANETTE	277.05	Pay period 02/01/2025 to 02/02/2025
V641	02/13/2025	STONER, SHANNON	1,342.94	Pay period 01/27/2025 to 02/02/2025
V641	02/13/2025	VAN STRATEN, ASHLEY	277.05	Pay period 02/01/2025 to 02/02/2025
V641	02/13/2025	WICKMAN, MATTHEW	1,653.83	Pay period 01/27/2025 to 02/02/2025
V641	02/13/2025	WINKLER, RANDY	109.18	Pay period 01/27/2025 to 02/02/2025

V641 02/13/2025	YOUNG, MATTHEW	277.05	Pay period 02/01/2025 to 02/13/2025
V641 02/27/2025	AMMERMAN, ANN	420.37	Pay period 02/10/2025 to 02/27/2025
V641 02/27/2025	AMMERMAN, THOMAS	267.81	Pay period 02/10/2025 to 02/27/2025
V641 02/27/2025	ANDERSON, CHELSEA	1,580.70	Pay period 02/10/2025 to 02/27/2025
V641 02/27/2025	ANDERSON, ERIC	894.71	Pay period 02/10/2025 to 02/27/2025
V641 02/27/2025	ANDERSON, LISA	676.48	Pay period 02/10/2025 to 02/27/2025
V642 02/27/2025	ANDERSON, LORI	116	Pay period 02/10/2025 to 02/27/2025
V642 02/27/2025	ANDERSON, NATHAN	1,922.65	Pay period 02/10/2025 to 02/27/2025
V642 02/27/2025	BLASER, MARIE A	112	Pay period 02/10/2025 to 02/27/2025
V642 02/27/2025	BRAUN, ALLISON	875.6	Pay period 02/10/2025 to 02/27/2025
V642 02/27/2025	BREITENBACH, SHANE	1,722.74	Pay period 02/10/2025 to 02/27/2025
V642 02/27/2025	BUBOLZ, BETTY M	100	Pay period 02/10/2025 to 02/27/2025
V642 02/27/2025	CHRISTENSEN, LEONE M	27.09	Pay period 02/10/2025 to 02/27/2025
V642 02/27/2025	CHRISTENSEN-ELECTI, LEONE M	80.75	Pay period 02/10/2025 to 02/27/2025
V642 02/27/2025	COVERT, AUTUMN R	104	Pay period 02/10/2025 to 02/27/2025
V642 02/27/2025	COX, KATHERINE	246.21	Pay period 02/10/2025 to 02/27/2025
V643 02/27/2025	GABLE, RUSSELL	1,657.37	Pay period 02/10/2025 to 02/27/2025
V643 02/27/2025	GRZYWACZ, CHRISTY	476.33	Pay period 02/10/2025 to 02/27/2025
V643 02/27/2025	HULL, ASHLEY N	1,855.84	Pay period 02/10/2025 to 02/27/2025
V643 02/27/2025	KURTZ, KATELYN	257.46	Pay period 02/10/2025 to 02/27/2025
V643 02/27/2025	SMITH, KEVIN	112	Pay period 02/10/2025 to 02/27/2025
V643 02/27/2025	STONER, SHANNON	1,342.94	Pay period 02/10/2025 to 02/27/2025
V643 02/27/2025	WICKMAN, MATTHEW	1,791.56	Pay period 02/10/2025 to 02/27/2025
V643 02/27/2025	WINKLER, RANDY	109.18	Pay period 02/10/2025 to 02/27/2025
DEFCC 02/13/2025	WISCONSIN DEFERRED COMPENSATI 120		Record Deferred Comp PR 2.1
DEFCC 02/27/2025	WISCONSIN DEFERRED COMPENSATI 120		To record Deferred Comp PR 2.1
DEPTR 02/04/2025	WISCONSIN DEPARTMENT OF REVENUE 732.44		Record State Withholding PR 2.1
DEPTR 02/13/2025	WISCONSIN DEPARTMENT OF REVENUE 830.95		Record state withholding PR 2.1
DEPTR 02/27/2025	WISCONSIN DEPARTMENT OF REVENUE 827.99		To record state withholding PR 2.1
2172025 02/17/2025	DELTA DENTAL ACH	352.54	JANUARY DENTAL
2202025 02/03/2025	GILLETT WATER & SEWER - EFT	910.85	
2242025 02/24/2025	HEALTH INSURANCE WI DEPT OF ETF 18,580.80		MARCH 2025 Premiums

## UTILITY

Check N	Check Date	Vendor name	Check Amount	Transaction memo
5245	02/04/2025	ASTREA	195.05	INTERNET
5246	02/04/2025	BADGER METER	1,242.39	
5247	02/04/2025	DEPARTMENT OF NATURAL RESOUF 25		MATT WICHMAN
5248	02/04/2025	MCCLONE	849.47	W/COMP INS -
5249	02/13/2025	BUMPER TO BUMPER	604.81	
5250	02/13/2025	BUSINESS CARD	51.6	INDEED POSITION
5251	02/13/2025	BUSINESS CARD	1,719.64	VOICESHOT
5252	02/13/2025	DEPARTMENT OF NATURAL RESOUF 25		MATT WICHMAN
5253	02/13/2025	GFC LEASING - WI GORDON FLESCI 30		COPIER LEASE
5254	02/13/2025	GILLETT HARDWARE	351.04	ACCT# 1160
5255	02/13/2025	HYDROCORP	1,151.00	
5256	02/18/2025	HAWKINS INC	3,362.42	
5257	02/19/2025	DIGGERS HOTLINE	5.4	INVOICE#250-1-74401
5258	02/19/2025	OCONTO ELECTRIC	2,356.57	ACCOUNT#617503
5259	02/19/2025	SAVECO NORTH AMERICA INC.	1,068.89	INVOICE # PART24308-00-PL
5260	02/26/2025	HAWKINS INC	60	
5261	02/26/2025	NEW MEDIA INC.	172.27	UTILITY ASSISTANT OPERATOR
5262	02/26/2025	ROBERT E LEE & ASSOCIATES, INC	34,211.64	STATE HWY 22 -PROFESSIONAL
5263	02/26/2025	ROGAN'S SHOES	165	INVOICE#299199
5264	02/26/2025	WE ENERGIES	817.39	INV#5662012711
5265	02/26/2025	WE ENERGIES	2,631.40	INV#5361482038
5266	02/27/2025	AT&T MOBILITY	348.9	UTIL- FEBRUARY
5267	02/27/2025	GILLETT POSTMASTER	282.24	WATER BILL DUE 3/20/25
2E+06	02/03/2025	GILLETT WATER & SEWER - EFT	31.76	



# Gillett Police Department

## Law Total Incident Report, by Nature of Incident

<u>Nature of Incident</u>	<u>Total Incidents</u>
911 Hangup	2
911 Open Line	2
Assist Other Agency	2
Alarm	1
Request for ambulance	5
Animal Problem	1
Building Check	69
Child Abuse	1
Citizen Assist	2
Citizen Dispute	1
Death Notification	1
Disturbance	5
Controlled Substance Problem	1
EM 1 Transport	1
Explosives Problem	1
Extra Patrol	42
Fire	1
Found Property	2
Harassment	3
Information Report	2
Juvenile Problem	5
Lockout	1
Open Records Request	3
Ordinance Violation	1
Parking Problem	1
Traffic Accident with Damage	1
Public Relations	1
School Safety Check	2
Suspicious Person, Circumstnce	3
Test Call	1
Threatening	2
Tobacco Problem	6
Traffic Accident-No Report	1
Traffic Miscellaneous	2
Traffic Violation	9
Traffic Stop	13
Truancy	6
Wanted Person	1
Welfare Check	2

Total reported: 206

### Report Includes:

All dates between `00:00:01 02/01/25` and `10:00:00 03/05/25`, All agencies matching `GPD`, All natures, All locations, All responsible officers, All dispositions, All clearance codes, All observed offenses, All reported offenses, All offense codes, All circumstance codes

## **FEBRUARY 2025 Monthly Report**

For the month of February, I responded to 24 law enforcement related calls between the secondary and elementary school. I also assisted with multiple student contacts.

I was able to recover 4 vapes from students on 9 calls

I had 2 contacts in regards to welfare checks outside of the school hours at student residences I had 1 EM1 call, multiple harassment/bullying calls.

I attended multiple basketball games with no incidents at the games. After the games I have multiple students come up and talk to me before leaving.

We had a K9 sweep of the school where 1 item of contraband was found.

I have been in contact with Human Services throughout the month to assist students that need help at home or with their mental health. I have been doing check in with certain student to see how they are doing in school and how home life is going.

I have been building relationships with the students and teachers in both schools. Students are aware they can come to me with issues and concerns. I have had multiple elementary school students that had spoken with me about home life and things law enforcement could do to make them feel safe. I have noticed multiple parents that have had negative contacts with the school now work on building relationships with staff to assist their child.

I have joined the Health Committee at school to assist students and staff with abuse, vaping, drugs, social media, anxiety, bullying.

I also will be the assistant coach for the girls' softball team.

I am working on a program in the Elementary school to acknowledge students that go above and beyond to make a difference in school.

I participated in the FFA assembly for the teacher's team and peddled a mini tractor around the gym, did a cowpie eating contest, and played farmer's basketball.

I have issued 11 citations this month. 3 for vaping, 1 disorderly conduct, and 7 truanancies.

I have multiple meetings set up with Oconto County Human Services and other organizations to build presentations for the students on Teen Distracted Driving, Mental Health, Bullying, Secure Detention, Abuse, Sexual Assault, and Harassment. Also going through the law side with citations, court, and jail/juvenile intake.

# Application for Temporary Class "B" / "Class B" Retailer's License

See Additional Information on reverse side. Contact the municipal clerk if you have questions.

Fee \$ \_\_\_\_\_ Application Date: 1-6-2025  
 Town  Village  City of Gillett County of Oconto

The named organization applies for: (check appropriate box(es).)

- A Temporary Class "B" license to sell fermented malt beverages at picnics or similar gatherings under s. 125.26(6), Wis. Stats.  
 A Temporary "Class B" license to sell wine at picnics or similar gatherings under s. 125.51(10), Wis. Stats.

at the premises described below during a special event beginning \_\_\_\_\_ and ending \_\_\_\_\_ and agrees to comply with all laws, resolutions, ordinances and regulations (state, federal or local) affecting the sale of fermented malt beverages and/or wine if the license is granted.

1. Organization (check appropriate box) →  Bona fide Club  Church  Lodge/Society  
 Chamber of Commerce or similar Civic or Trade Organization  
 Veteran's Organization  Fair Association

(a) Name Gillett Civic Club

(b) Address \_\_\_\_\_  
(Street)  Town  Village  City

(c) Date organized 1939

(d) If corporation, give date of incorporation \_\_\_\_\_

(e) If the named organization is not required to hold a Wisconsin seller's permit pursuant to s. 77.54 (7m), Wis. Stats., check this box:

(f) Names and addresses of all officers:

President Keith Sorlie

Vice President Dave Hennrichs

Secretary Wendy Vorpehl

Treasurer Cliff Gerbers

(g) Name and address of manager or person in charge of affair: Ann Hennrichs  
6280 Iditarod Trl Lena WI 54139

2. Location of Premises Where Beer and/or Wine Will Be Sold, Served, Consumed, or Stored, and Areas Where Alcohol Beverage Records Will be Stored: Zippel Park Gillett

(a) Street number \_\_\_\_\_ Block \_\_\_\_\_

(b) Lot \_\_\_\_\_

(c) Do premises occupy all or part of building? \_\_\_\_\_

(d) If part of building, describe fully all premises covered under this application, which floor or floors, or room or rooms, license is to cover: \_\_\_\_\_

3. Name of Event

(a) List name of the event Gillett 4th of July Celebration

(b) Dates of event July 3 & 4 2025

### DECLARATION

The Officer(s) of the organization, individually and together, declare under penalties of law that the information provided in this application is true and correct to the best of their knowledge and belief.

Officer [Signature]  
(Signature/date)

Officer [Signature]  
(Signature/date)

Date Filed with Clerk \_\_\_\_\_

Date Granted by Council \_\_\_\_\_

Gillett Civic Club  
(Name of Organization)

Officer Ann Hennrichs 4th July Chair  
(Signature/date)

Officer \_\_\_\_\_ 4th of July  
(Signature/date)

Date Reported to Council or Board \_\_\_\_\_

License No. \_\_\_\_\_



**City of Gillett**  
150 N McKenzie Avenue  
Gillett, Wisconsin 54124  
P (920) 855-2255  
F (920) 855-6283

## City of Gillett Life Insurance Policy

### Life Insurance

The City of Gillett will pay the full premium of the basic life insurance policy through the Wisconsin Public Employers Group Life Insurance Program. Additional coverage is available and will be paid for by the employee.

If you are enrolled in the Group Life Insurance Program and are eligible to continue your coverage after you retire, your life insurance will be continued automatically. Premiums will be deducted from your monthly annuity.

The City reserves the right to change the plan or carriers at any time. Participation in the plan is subject to all requirements imposed by the carrier.

This Policy shall be effective upon passage.

Adopted this the 6<sup>th</sup> day of March, 2025

---

Mayor Jon Blaskowski

---

Chelsea Anderson  
Clerk/Treasurer

State Bar of Wisconsin Form 3-2003  
**QUIT CLAIM DEED**

Document Number

Document Name

**THIS DEED**, made between Gillett Industrial Development Corporation n/k/a  
City of Gillett, a municipal corporation  
 \_\_\_\_\_ ("Grantor," whether one or more),  
 and L&N Metal Works LLC, a Wisconsin limited liability company  
 \_\_\_\_\_ ("Grantee," whether one or more).

Grantor quit claims to Grantee the following described real estate, together with the rents, profits, fixtures and other appurtenant interests, in Oconto County, State of Wisconsin ("Property") (if more space is needed, please attach addendum):

All of Lot 6 of the City of Gillett Assessor Plat Number 3, located in part of the Southwest quarter of the Northeast quarter and part of the Southeast quarter of the Northeast quarter of Section 21, Township 28 North, Range 18 East, City of Gillett, Oconto County, Wisconsin, subject to a drainage and utility easement including a storm sewer, over and across the Easterly 15 feet to the Southerly 210 feet thereof.

Together with and subject to any other easements, covenants, and restrictions of record.

Recording Area

Name and Return Address

Attorney Robert R. Gagan  
 Law Firm of Conway, Olejniczak & Jerry, S.C.  
 PO Box 23200  
 Green Bay, WI 54305

231012116106

Parcel Identification Number (PIN)

This \_\_\_\_\_ is not \_\_\_\_\_ homestead property.  
 (is) (is not)

Dated \_\_\_\_\_

Gillett Industrial Development Corporation n/k/a City of Gillett

\_\_\_\_\_(SEAL) \_\_\_\_\_(SEAL)

\* \_\_\_\_\_ \*

\_\_\_\_\_(SEAL) \_\_\_\_\_(SEAL)

\* \_\_\_\_\_ \*

**AUTHENTICATION**

Signature(s) \_\_\_\_\_

authenticated on \_\_\_\_\_

\* \_\_\_\_\_

TITLE: MEMBER STATE BAR OF WISCONSIN

(If not, \_\_\_\_\_  
 authorized by Wis. Stat. § 706.06)

THIS INSTRUMENT DRAFTED BY:

Attorney Robert R. Gagan

Law Firm of Conway, Olejniczak & Jerry, S.C.

**ACKNOWLEDGMENT**

STATE OF WISCONSIN )  
 ) ss.  
 \_\_\_\_\_ COUNTY )

Personally came before me on \_\_\_\_\_,  
 the above-named \_\_\_\_\_

to me known to be the person(s) who executed the foregoing instrument and acknowledged the same.

\* \_\_\_\_\_

Notary Public, State of Wisconsin  
 My Commission (is permanent) (expires: \_\_\_\_\_)

(Signatures may be authenticated or acknowledged. Both are not necessary.)

NOTE: THIS IS A STANDARD FORM. ANY MODIFICATIONS TO THIS FORM SHOULD BE CLEARLY IDENTIFIED.

QUIT CLAIM DEED

© 2003 STATE BAR OF WISCONSIN

FORM NO. 3-2003

\* Type name below signatures.



PAUL R. SHALLOW, PLS  
 P.O. BOX 88  
 LENA, WI 54139  
 920-834-5225

Account #3468  
 Dwg. No. 3468LANDN

# SHALLOW LLC SURVEYING

Professional Wisconsin Land Surveyor

## PLAT OF SURVEY

ALL OF LOT 6 OF THE CITY OF GILLETT ASSESSOR PLAT NUMBER 3, LOCATED IN PART OF THE SOUTHWEST QUARTER OF THE NORTHEAST QUARTER AND PART OF THE SOUTHEAST QUARTER OF THE NORTHEAST QUARTER OF SECTION 21, TOWNSHIP 28 NORTH, RANGE 18 EAST, CITY OF GILLETT, OCONTO COUNTY, WISCONSIN.

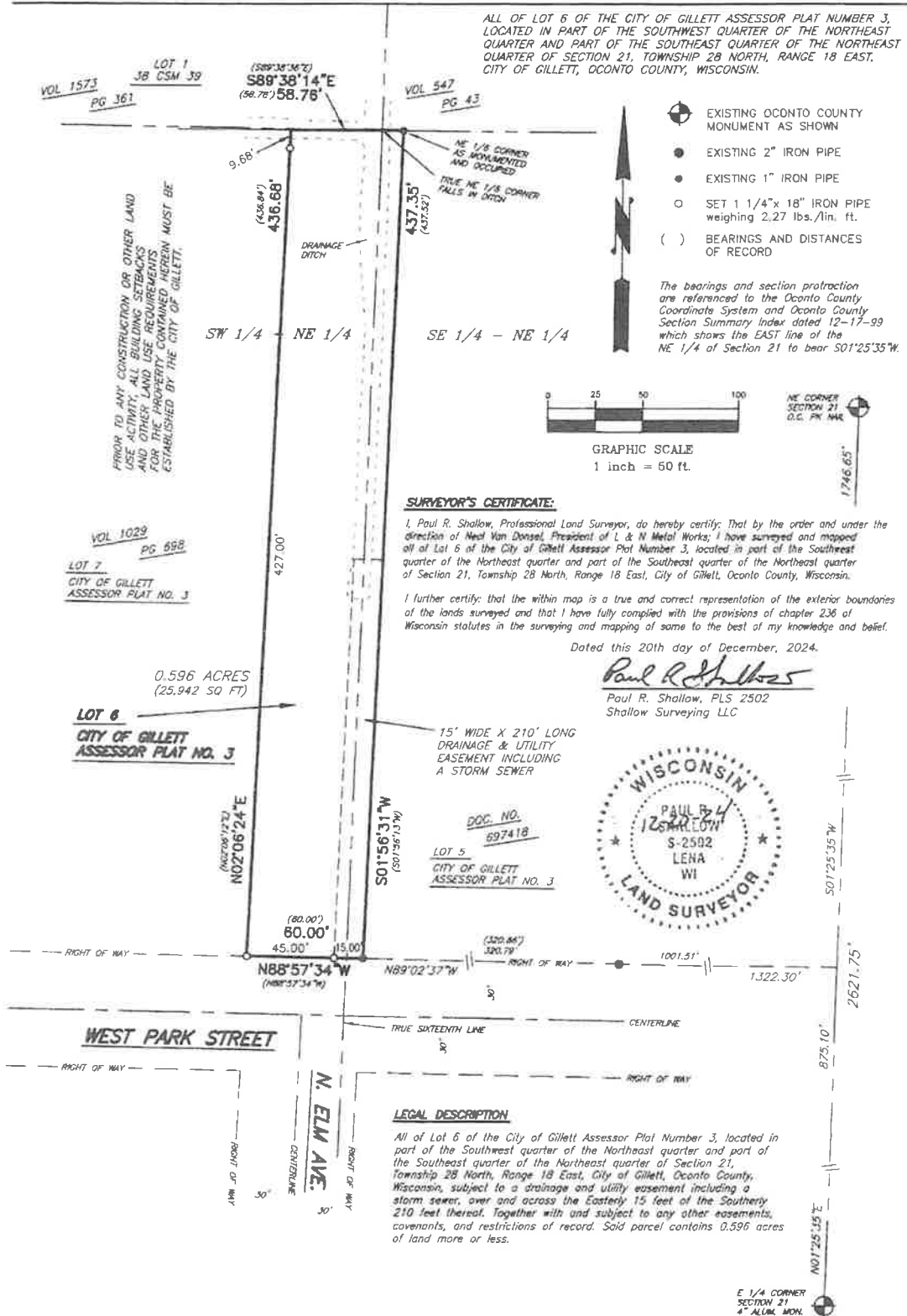



**Department of Safety  
& Professional Services,  
Industry Services Division**

County **Oconto**  
Sanitary Permit Number (to be filled in by Co.)

**Sanitary Permit Application**

In accordance with SPS 383.21(2), Wis. Adm. Code, submission of this form to the appropriate governmental unit is required prior to obtaining a sanitary permit. Note: Application forms for state-owned POWTS are submitted to the Department of Safety and Professional Services. Personal information you provide may be used for secondary purposes in accordance with the Privacy Law, s. 15.04(1)(m), Stats.

State Transaction Number  
Project Address (if different than mailing address)  
**125 E. Fourth St**

**I. Application Information – Please Print All Information**

Property Owner's Name  
**Jim and Nancy Van Elzen**

Parcel #  
**231-0422213550**

Property Owner's Mailing Address  
**N 3066 Cty Rd C**

Property Location  
Govt. Lot \_\_\_\_\_

City, State  
**Pulaski, WI**

Zip Code  
**54162**

Phone Number

**SW 1/4, SW 1/4, Section 22**

**II. Type of Building (check all that apply)**

- 1 or 2 Family Dwelling – Number of Bedrooms **2**
- Public/Commercial – Describe Use \_\_\_\_\_
- State Owned – Describe Use \_\_\_\_\_

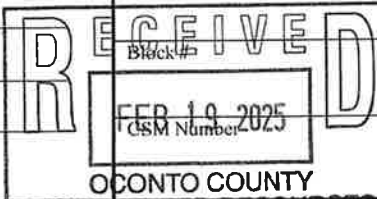

Lot #

**T 28 N R 18 E or W**

Subdivision Name

- City of **Gillett**
- Village of \_\_\_\_\_
- Town of \_\_\_\_\_

**III. Type of POWTS Permit: (Check either "New" or "Replacement" and other applicable on line A. Check one box on line B. Complete line C if applicable.)**

- A.  New System     Replacement System     Other Modification to Existing System (explain)     Additional Pretreatment Unit (explain)
- B.  Holding Tank     In-Ground (conventional)     At-Grade     Mound     Individual Site Design     Other Type (explain)
- C.  Renewal Before Expiration     Revision     Change of Plumber     Transfer to New Owner
- List Previous Permit Number and Date Issued

**IV. Dispersal/Treatment Area and Tank Information:**

Design Flow (gpd)	Design Soil Application Rate(gpd/sf)	Dispersal Area Required (sf)	Dispersal Area Proposed (sf)	System Elevation						
<b>300</b>	<b>.4</b>	<b>750</b>	<b>750</b>	<b>94.3</b>						
Tank Information	Capacity in Gallons		Total Gallons	# of Units	Manufacturer	Prefab Concrete	Site Constructed	Steel	Fiber Glass	Plastic
	New Tanks	Existing Tanks								
Septic or Holding Tank	<b>1000</b>			<b>1</b>	<b>Murphy Concrete</b>	<b>X</b>				
Dosing Chamber										

**V. Responsibility Statement- I, the undersigned, assume responsibility for installation of the POWTS shown on the attached plans.**

Plumber's Name (Print) **Nevin Landis**    Plumber's Signature *Nevin Landis*    MP/MPRS Number **954943**    Business Phone Number \_\_\_\_\_

Plumber's Address (Street, City, State, Zip Code)  
**7423 Fairview Rd Oconto, WI 54153**

**VI. County/Department Use Only**

Approved     Disapproved     Owner Given Reason for Denial    Permit Fee \$ \_\_\_\_\_    Date Issued \_\_\_\_\_    Issuing Agent Signature \_\_\_\_\_

Conditions of Approval/Reasons for Disapproval  
  
**Ensure lot lines are clearly marked to meet setbacks**

Attach to complete plans for the system and submit to the County only on paper not less than 8 1/2 x 11 inches in size

**NOTIFICATION OF OCONTO COUNTY  
MAINTENANCE REQUIREMENTS AND WISCONSIN FUND PROGRAM**

Jim and Nancy Van Elzen  
Name of Property Owner

N 3066 Cty Rd C  
Home Mailing Address

Pulaski, WI 54602  
City, State, Zip Code

\_\_\_\_\_  
Property Owner's Phone Number

125 E. Fourth Street  
Physical Address (if different from Mailing Address)

231-0422213550  
Parcel Number of Property (Location on Tax Bill)

In accordance with WI Administrative Code DSPS 383.52 all Privately Owned Wastewater Treatment Systems (POWTS) shall be maintained. The owner of a POWTS shall be responsible for ensuring the operation and maintenance of the POWTS occurs in accordance with DSPS 383 and the approved management plan detailed in the sanitary permit.

POWTS that exists prior to July 1, 2000 shall be visually inspected at least once every 3 years to determine whether wastewater or effluent from the POWTS is ponding on the surface of the ground. Servicing of the treatment tank shall occur at least when the combined sludge and scum volume equals 1/3 of the tank volume.

The servicing of a holding tank shall occur at least when the wastewater of the tank reaches a level of one foot below the inlet invert of the tank.

Pending a change in monitoring the required maintenance, Oconto County will send maintenance notification at the service interval required for your POWTS. If you have servicing completed prior to your notification date, contact the Oconto County Zoning Office and we will provide you with a maintenance card to be completed and returned.

A POWTS, including a POWTS existing prior to July 1, 2000, that is not maintained in accordance with the approved management plan or as required under s. DSPS 383.54(4) shall be considered a human health hazard.

**Replacement Systems:**

Oconto County participates in the Wisconsin Fund (Private Sewage System Replacement or Rehabilitation Grant Program). This fund provides financial incentives to protect and improve public health, safety and groundwater quality in Wisconsin. If your principle residence or small business POWTS failure is classified as a Category 1 (systems discharging to surface water, groundwater, etc.) or Category 2 (systems discharging to ground surface) as designated by a County Zoning representative, you may be eligible for a grant under this program provided that all of the following requirements are met:

- 1) The failure of your POWTS is classified as Category 1 or 2 failure by a County Zoning representative prior to replacement of the existing POWTS.
- 2) The residence is your principle residence (occupied greater than 51% of the year).
- 3) The failing POWTS was constructed prior to July 1, 1978.
- 4) The residence is not located in an area served by a municipal sewer.
- 5) The income of all owners of the principle residence is less than \$45,000 and for small commercial establishments less than \$362,500.

Check this box if you intend to apply for the Wisconsin Fund. Condition #1 must be verified prior to replacement of the existing system.

I, the undersigned, am the owner of the above stated property and agree to comply with the maintenance requirements as stated above and will notify any future assignees of my property of this Maintenance Program. I further agree to allow free and unlimited access to the above described property at anytime by a County Zoning representative who is investigating compliance with the State Statutes and/or County Codes.

Agent / Nevin Landis  
Signature of Property Owner

2-12-25  
Date

NOTE: The ORIGINAL copy of this document must accompany the Sanitary Permit Application.

# In-Ground Gravity Plan Index & Cover Sheet

Component Manual Design References:  
Version 2.0, SBD-10705-P (N.01/01, R. 10/12)

<b>Pg 1 of 4</b>	Index & Cover Sheet
<b>Pg 2 of 4</b>	Plot Plan
<b>Pg 3 of 4</b>	Dispersal Area Cross-Section & Plan View
<b>Pg 4 of 4</b>	Management Plan

<u>Attachments:</u>	<u>Enclosures:</u>
	POWTS Application for Review
	Soil Evaluation Report & Site Map

### Project Name / Description

Van Elzen

Owner Name(s): Jin and Nancy Van Elzen Phone:           -      -        
 Owner Address: N3066 County Rd C Pulaski ,WI Zip: 54162  
 Project Address: 125 E. Fourth Street Gillett, WI  
 Govt. Lot:        SW 1/4 of SW 1/4, Section 22, T 28 N-R 18 E  or W   
 Township: City of Gillet County: Oconto  
 Project Parcel ID #: 231-0422213550

### Designer Information

Designer Name: Nevin Landis Phone:           -      -        
 Designer Address: 7423 Fairview rd Oconto,WI Zip: 54153  
 E-mail: Landexcavating@emypeople.net  
 License Number: 954943

Remarks:

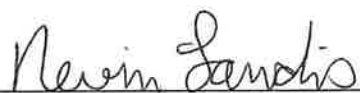
Signature:  Date: 2-12-2025  
Original signature required on each submitted copy.

Jim & Nancy Van Elzen  
 N3066 County Road C  
 Pulaski, WI 54162

Legal Description:  
 SW, SW, Sec. 22, T28N, R18E  
 City of Gillett, Oconto County  
 Wisconsin

Tax Id.#: 231-0422213550

Land Use: Wooded

Parcel Size: 2.0 Acres

Site Location: E 4th Street

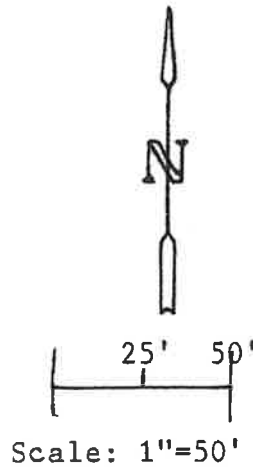

KEY

- Soil pits
- ☼ TBM=100' (Top of nail 8" above Grade in Maple tree)

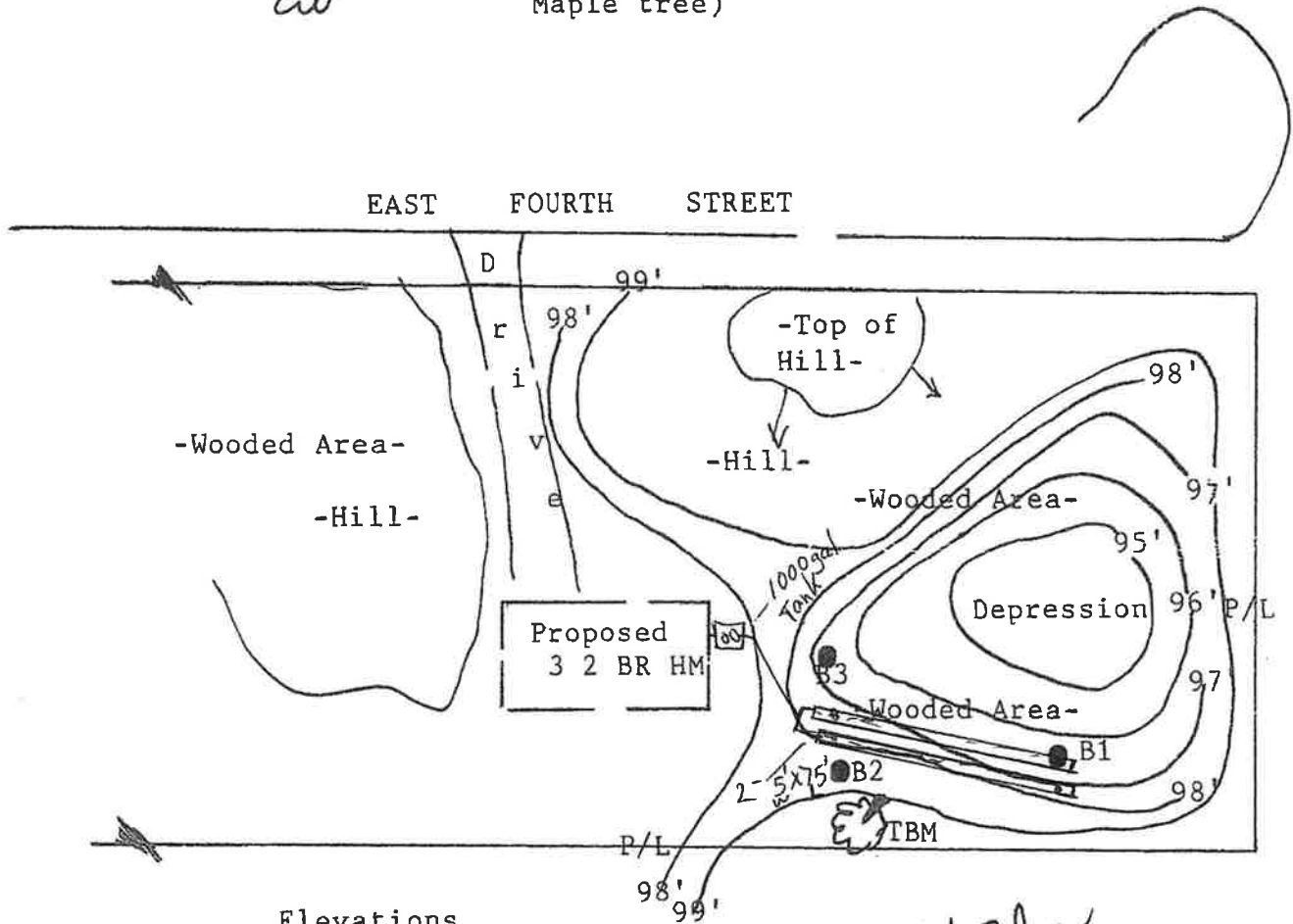

Elevations

- B1 = 96.28'
- B2 = 98.12'
- B3 = 96.78'

*Jeffrey Zelen*  
 CSST # 222240

# Septic Tank Cross Section and Specifications

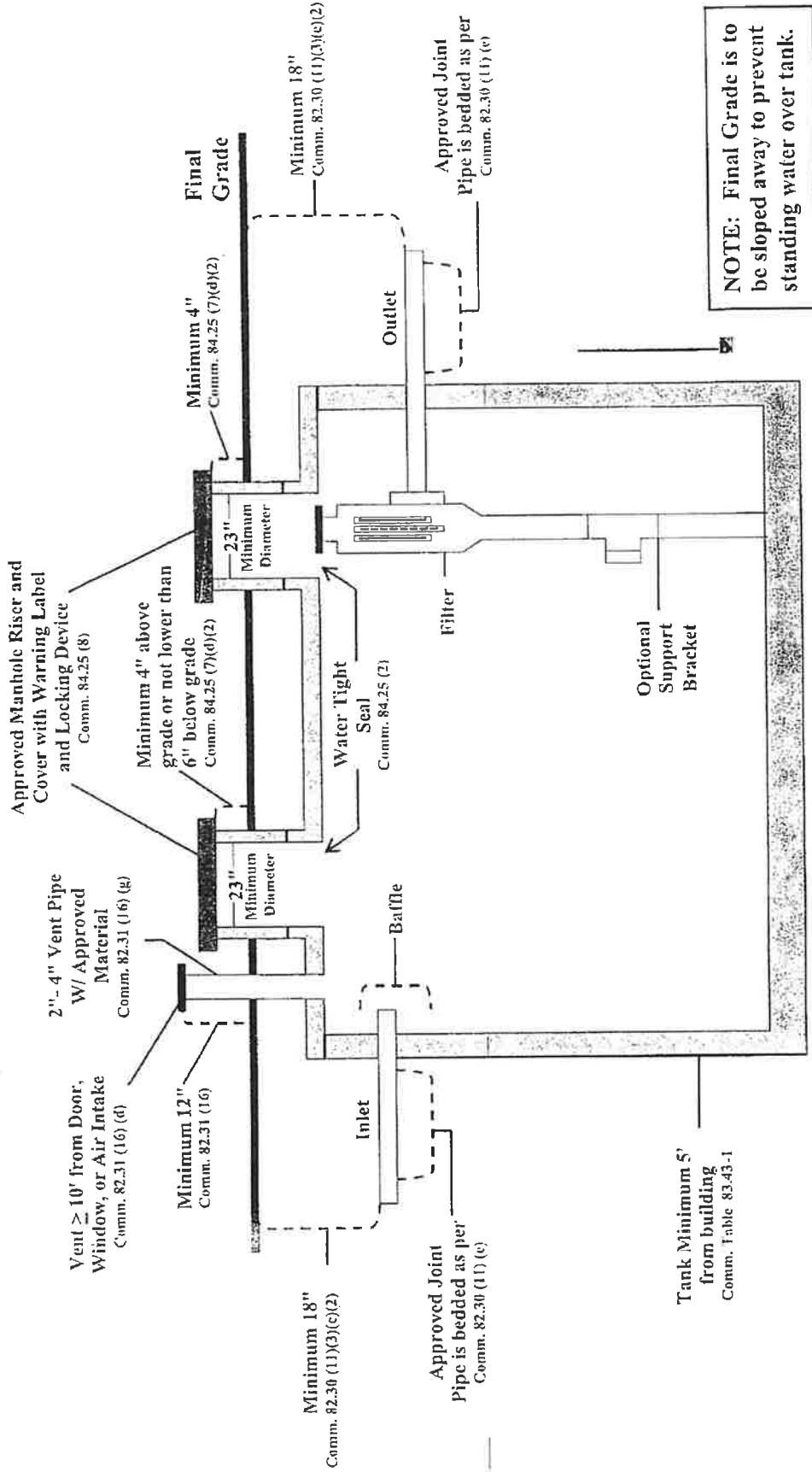

**NOTE: Final Grade is to be sloped away to prevent standing water over tank.**

Bedding Under Tank as per Manufacturer's Specifications

**Specifications**

Tanks Manufacturer: Murphy Concrete Tank Model No.: 1000

Tank Size: 1000 Gallons

Filter Manufacturer: Polylok Filter Model No.: 525

Filter Size: \_\_\_\_\_

111 100100001 - Form 845-AMTADV-RODAPIC-AMTADV-RODAPIC-AMTADV-Tank-Cross-Section.dwg

1000 Gallon Single Compartment Septic, Holding or Pump

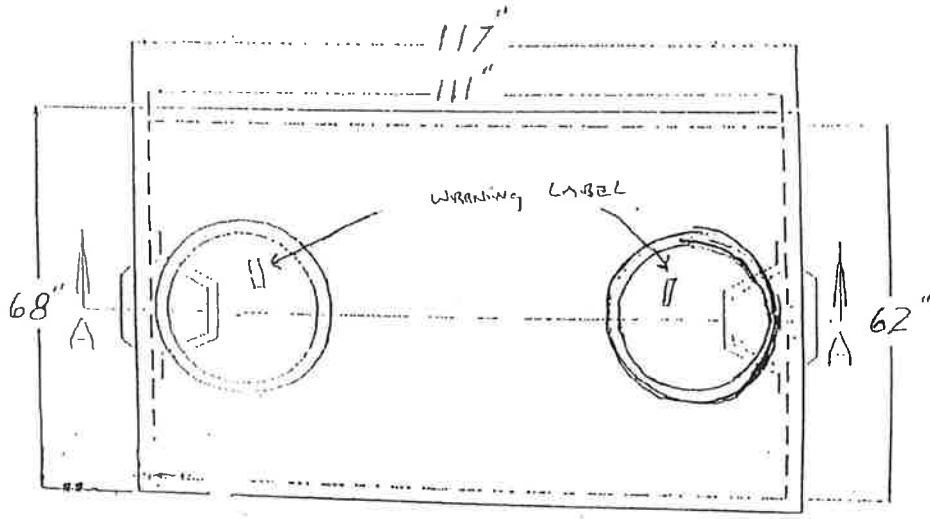

TOP VIEW

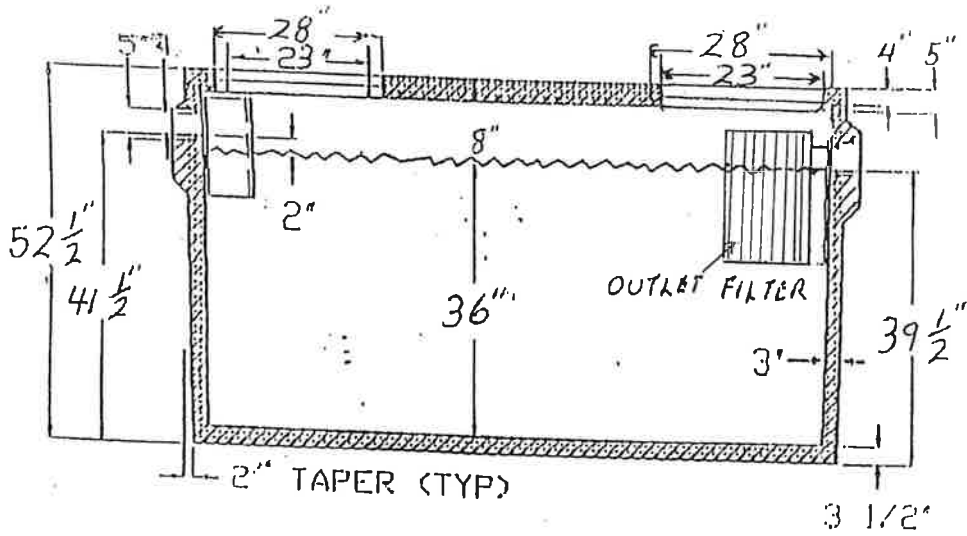

SECTION A-A

MFG. FOR MURPHY :

MURPHY PRECAST PRODUCTS LLC  
1000 Gallon Single Compartment  
Septic, Holding or Pump

**APPROVED**

By Glen Schlueter at 9:59 am, May 02, 2022



Department of Safety and Professional Services  
Division of Industry Services  
Plumbing Product Review  
4822 Madison Yards Way  
P.O. Box 7162  
Madison, Wisconsin 53707-7162  
Phone 608-266-2112  
Web <http://dsps.wi.gov>  
Email [dsps@wisconsin.gov](mailto:dsps@wisconsin.gov)  
TTY: Contact Through Relay

Governor Tony Evers Dawn Crim, Secretary

May 2, 2022

Murphy Precast Products LLC  
Cameron J. Murphy  
1840 Cypress Rd.  
De Pere WI 54115

Re: Description: Sewage Tanks, Concrete  
Manufacturer: Murphy Precast Products LLC  
Product Name: Single-Compartment Holding, Pump or Septic Tanks: 1000 and 1253  
Model Number(s): Single-Compartment Holding, Pump or Septic Tanks: 1000 and 1253  
eSLA PTO No.: PP-052200017-PTOPHTC

The specifications and/or plans for these sewage tanks have been reviewed and determined to be in compliance with chapters SPS 382 through 384, Wisconsin Administrative Code, and Chapters 145 and 160, Wisconsin Statutes.

The Department hereby issues an approval based on the Wisconsin Statutes and the Wisconsin Administrative Code. This approval is valid until the end of May 2027. This approval is contingent upon compliance with the following stipulation(s):

1. These tanks shall:
  - a. conform to s. SPS 384.25 (2) (b) Wis. Adm. Code.
  - b. be labeled as required by s. SPS 384.25 (11) (c) Wis. Adm. Code.
  - c. be placed in accordance with s. SPS 383.43(8)(i) Wis. Adm. Code.
  - d. be designed to withstand the pressures to which they are subjected.
  - e. be fitted with locking manhole covers in accordance with s. SPS 384.25 (7) (h) Wis. Adm. Code. The manhole cover must be secured to the riser using screws which are not standard or Philips head to be considered an effective locking device.
  - f. bear warning labels, that are visible after installation, that conform to s. SPS 384.25 (8).
  - g. be anchored in accordance with s. SPS 383.43 (8) (g) Wis. Adm. Code when installed in areas subject to saturated soil conditions.
  - h. be installed by persons holding the proper license or registration in accordance with Wis. Stats. § 145.
  - i. be installed, maintained and used in strict accordance with the manufacturer's published instructions, Chapters 381-387 Wis. Adm. Code and this product approval. If there is a conflict between the manufacturer's instructions and the Wis. Adm. Code or this Plumbing Product Approval, then the Wis. Adm. Code and this Plumbing Product Approval shall take precedence.
2. DSPS POWTS plan approval shall be obtained from the department's Private Sewage Section, or the appropriate agent county, for each installation of these devices.
3. A sanitary permit shall be obtained, in accordance with s. SPS 383.21 Wis. Adm. Code, from the county, or other local authority having jurisdiction, for each proposed installation of these tanks.

No person shall purchase, or install, a private on-site wastewater treatment system unless the owner of the property on which the private on-site wastewater treatment system is to be installed holds a valid sanitary permit issued under § 145.19.

No person shall sell at retail, as defined under § 100.201 (1) (d), a septic tank for installation in this state unless the purchaser holds a valid sanitary permit issued under § 145.19.



4. Campgrounds shall obtain required permitting from the Wisconsin Department of Health Services under HFS 178 prior to installing or using these tanks.
5. Drain, waste and vent piping used to install these tanks shall conform to s. SPS 384.30 (1), (2) and (3) Wis. Adm. Code.
6. Cleanouts shall be installed in drain piping associated with the installation of these tanks in accordance with s. SPS 382.35 Wis. Adm. Code.
7. Tank contents removed shall be treated as septage and disposed of in accordance with NR 113 Wis. Adm. Code.
8. This approval shall not include consideration of these tanks for any fresh/potable water uses.
9. The manufacturer must keep at the manufacturing plant a set of plans and specifications bearing the department's stamp of approval. The plans and specifications must be open to inspection by an authorized representative of the department.
10. Backfill for these tanks shall:
  - a. be soil material;
  - b. pass a 4-in. screen; and
  - c. be tamped into place.
11. Bedding for these tanks shall:
  - a. be  $\geq$  3-in. thick;
  - b. be leveled and compacted;
  - c. be comprised of sand, gravel, granite, limestone or other non-corrosive material; and
  - d. pass a  $\frac{3}{4}$ -in. screen.
12. The following are approved for use with these tanks:
  - a. 4-in. and 6-in. I.D. inlet, outlet and vent openings;
  - b. 4 in. and 6-in. ASTM C923/C923M-20 compliant pipe connectors;
  - c. 4-in. and 6-in. ASTM D1785-15 compliant PVC outlet hubs cast in walls;
  - d. watertight electrical openings  $\leq$  2-in. ID in access risers;
  - e. precast concrete access risers and covers;
  - f. ASTM C990-09 (R2019) compliant preformed flexible joint sealants; and
  - g. approved effluent filters installed in the outlet baffle.

Single Compartment Tank Specifications				
Model	Liquid Level (in.)	Gal./in.	Gal./day*	Max. Depth of Bury (in.)
1000	36.0	28.0	480	48
1253	49.0	25.6	601	48

\* = Based on a 3-yr. Service Interval for Residential Wastewater

Technical notations:

- a. This approval supersedes the approval issued March 27, 2022 under eSLA PTO no. PP-032200008-PTOPHTC and April 17, 2017 under eSLA PTO no. PP-041705797-PTOPHTC.

Murphy Precast Products LLC  
May 2, 2022  
Page 3 of 3  
eSLA PTO No.: PP-052200017-PTOPHTC

The department is in no way endorsing these tanks or any advertising and is not responsible for any situation which may result from their use.

Sincerely,

Glen W. Schlüter  
Plumbing Product Reviewer  
Department of Safety and Professional Services  
Division of Industry Services  
Bureau of Technical Services  
(608) 267-1401 **Phone**  
glen.schlueter@wi.gov **E-mail**  
7:45AM-4:30PM CDT M-F **Work Hours**

# IN-GROUND GRAVITY DISPERSAL AREA

## Uniform Elevation Trenches with Washed Aggregate

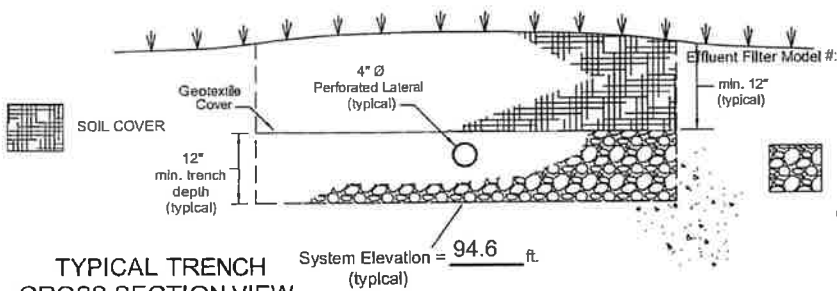

TYPICAL TRENCH  
CROSS SECTION VIEW  
(No Scale)

System Elevation = 94.6 ft.  
(typical)

Provide minimum 3 ft  
separation between trenches.

Septic Tank(s) Manufacturer:  
Murphy Concrete

Septic Tank(s) Volume(s):  
1000 gal         gal         gal         gal

Effluent Filter Manufacturer:  
Polylok 525

Effluent Filter Model # \_\_\_\_\_

0.5" TO 2.5" WASHED AGGREGATE  
(min. 6.0" beneath distribution pipe  
- min. 2.0" over distribution pipe and  
covered with approved synthetic fabric)

### OBSERVATION PIPE DETAIL (No Scale)

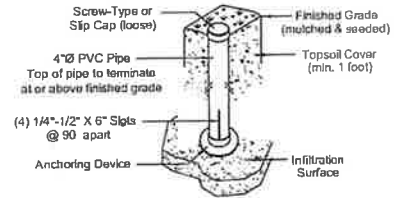

TYPICAL TRENCH  
PLAN VIEW  
(No Scale)

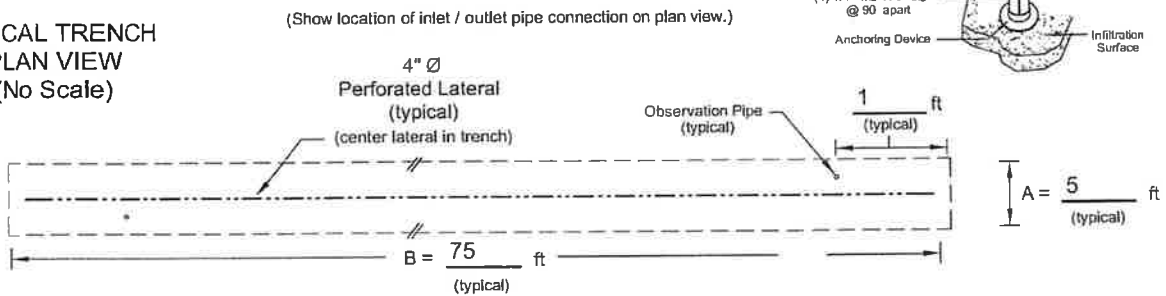

Required Infiltration Area = 750 ft<sup>2</sup>

Distribution Method:  
branched manifold

Proposed Total Infiltration Area = 375 ft<sup>2</sup> per trench x 2 trenches = 750 ft<sup>2</sup>

**RESET**

# In-ground Gravity Management Plan

## IMPORTANT:

The owner of this in-ground gravity system shall be responsible for its perpetual operation and maintenance pursuant to requirements of SPS 382-384, Wisc. Admin. Code. Pursuant to SPS 383.52 (2), Wisc. Admin. Code, this system shall be considered a human health hazard if not maintained in accordance with this approved management plan. Furthermore, all inspection and maintenance activities shall be performed by a **registered POWTS Maintainer** in accordance with SPS 383.52 (3), Wisc. Admin. Code.

## Maximum Dispersal Area Operating Limits:

Design Flow = ~~450~~ 300 gpd; BOD<sub>5</sub> ≤ 220 mgL<sup>-1</sup>; TSS ≤ 150 mgL<sup>-1</sup>; FOG ≤ 30 mgL<sup>-1</sup>

## Inspection Checklist

**INSPECT EVERY 3 YEARS**

- o type of use
- o age of system
- o nuisance factors (*i.e.* odors, user complaints, *etc.*)
- o mechanical malfunction (*i.e.*, pumps, valves, switches, floats, *etc.*)
- o material fatigue (*i.e.*, leaks, breaks, corrosion, *etc.*)
- o solids volume in anaerobic treatment tank(s) and any distribution appurtenance(s) (*i.e.*, distribution / drop boxes)
- o neglect or improper use (*i.e.*, exceeding design capacities, prohibited activities, *etc.*)
- o extent of ponding in distribution cell prior to dosing
- o dosing irregularities - if applicable (*i.e.*, pump re-cycling, float switch settings, *etc.*)
- o electrical components - if applicable (*i.e.*, wiring, connections, switches, controls, timers, alarms, *etc.*)
- o distribution lateral or lateral orifice plugging (measure lateral distal pressure – compare to design specification)
- o surface discharge of effluent or sewage back-up into structure served

## Maintenance Checklist

**MAINTAIN EVERY 3 YEARS (or when necessary)**

- o **Septic and dose tank(s)** shall be pumped by a certified septage servicing operator licensed under s. 281.48 Wis. Stats. **when the volume of solids in the tank(s) exceeds one-third (1/3) the liquid volume of the tank(s)** or as required by local ordinance. Disposal of contents shall be pursuant to NR 113, Wisc. Admin. Code.
- o **Effluent filter(s)** shall be inspected **every 3 years** and shall be cleaned **when necessary** to remove any accumulated solids according to manufacturer's specifications. A servicing period will always be greater than 12 months.

**System maintenance reports shall be submitted to the proper local government unit in accordance with SPS 383.55 Wisc. Admin. Code. Report any component failure or malfunction to:**

Name of individual or company: Landis Excavating LLC. Phone: 920-373-1193

Local government unit: Oconto County Zoning Phone: 920-834-6827

Local government unit address: 301 Washington Street ,Oconto,WI ZIP: 54153

Any defective part of this system shall be repaired, replaced, or removed pursuant to SPS 383.51 (1), Wisc. Admin. Code. Repair or replacement of failed or malfunctioning components shall comply with SPS 383, Wisc. Admin. Code. No product for chemical or physical restoration of the POWTS may be used unless approved by the department in accordance with SPS 384, Wisc. Admin. Code.

## Contingency Plan

In the event that any failed treatment component of this POWTS cannot be repaired, it shall be replaced pursuant to a plan submitted to the appropriate agency for review and approval. A failed in-ground dispersal component may be abandoned and replaced by a code-complying dispersal component in a pre-determined area of suitable soils.

## System Abandonment

If use of this POWTS is discontinued, it shall be abandoned in accordance with SPS 383.33, Wisc. Admin. Code.

SOIL EVALUATION REPORT

In accordance with SPS 385, Wis. Adm. Code

Attach complete site plan on paper not less than 8 1/2 x 11 inches in size. Plan must include, but not limited to: vertical and horizontal reference point (BM), direction and percent slope, scale or dimensions, north arrow, and location and distance to nearest road.

County OCONTO
Parcel I.D. 231-0422213550
Reviewed by <i>KB</i> Date <i>12/19/25</i>

Please print all information.

Personal information you provide may be used for secondary purposes (Privacy Law, s. 15.04(1)(m)).

Property Owner VAN ELZEN, JIM & NANCY				Property Location Govt. Lot SW 1/4 SW 1/4 S 22 T 28 N R 18 E (or) W			
Property Owner's Mailing Address N3066 COUNTY ROAD C				Lot # 2	Block # -	Subd. Name or CSM# -	
City PULASKI	State WI	Zip Code 54162	Phone Number (920) 655-3040	<input checked="" type="checkbox"/> City Gillett	<input type="checkbox"/> Village	<input type="checkbox"/> Town	Nearest Road E Fourth Street

New Construction Use:  Residential / Number of bedrooms 2 Code derived design flow rate 300 GPD  
 Replacement  Public or commercial - Describe: \_\_\_\_\_

Parent material Glacial Till Flood Plan elevation if applicable NA ft.

General comments and recommendations: Suggested a component manual Conventional cell design to utilize 750 Sqft of area for a 2 BR Home. Suggested system elev. 94.30'. Home foundation shall be raised or a lift pump may be required.

*oec2 Soil type*

**1** Boring #  Boring  Pit Ground surface elev. 96.28' ft. Depth to limiting factor 75 in.

Horizon	Depth In.	Dominant Color Munsell	Redox Description Qu. Az. Cont. Color	Texture	Structure Gr. Sz. Sh.	Consistence	Boundary	Roots	Soil Application Rate	
									GPD/Ft <sup>2</sup>	
									*Eff#1	*Eff#2
Ap	0-13	10YR3/4	-	LFS	2MGR	MFR	AS	2M	.5	1.0
Bs	13-26	7.5YR4/6	--	LFS	2MGR	MFR	CW	2F	.5	1.0
E/Bt	26-50	7.5YR6/2 & 4/4	--	SL	2MSBK	MFR	CW	2F	.6	1.0
C	50-75	7.5YR6/4	--	GRSL	MSV	MFR	--	--	.2	.6

**2** Boring #  Boring  Pit Ground surface elev. 98.12' ft. Depth to limiting factor 82.0 in.

Horizon	Depth In.	Dominant Color Munsell	Redox Description Qu. Az. Cont. Color	Texture	Structure Gr. Sz. Sh.	Consistence	Boundary	Roots	Soil Application Rate	
									GPD/Ft <sup>2</sup>	
									*Eff#1	*Eff#2
Ap	0-8	10YR3/2	--	SL	2MGR	MFR	AS	2M	.6	1.0
B/C	8-23	7.5YR6/4	--	GRSL	1FSBK	MFR	CW	2F	.4	.7
C	23-44	7.5YR6/4	--	SL	MSV	MFR	CW	1F	.2	.6
2C	44-82	7.5YR5/4	--	GRS	SG	ML	--	--	.7	1.6

\* Effluent #1 = BOD, > 30 ≤ 220 mg/L and TSS > 30 ≤ 150 mg/L \* Effluent #2 = BOD, > 30 ≤ 220 mg/L and TSS > 30 ≤ 150 mg/L

CST Name (Please Print) JEFFREY L. ZAHM	Signature <i>Jeffrey Zahm</i>	CST Number 223240
Address 6203 VANHULLE LANE, OCONTO, WI 54153	Date Evaluation Conducted February 20-2024	Telephone Number 920-373-1673



**City of Gillett**  
150 N McKenzie Avenue  
Gillett, Wisconsin 54124  
P (920) 855-2255  
F (920) 855-6283

**RESOLUTION FOR OUTDOOR RECREATION GRANT APPLICATIONS  
RESOLUTION # 1-2025**

**WHEREAS**, the City of Gillett is interested in acquiring or developing lands for public outdoor recreation purposes as described in the application; and

**WHEREAS**, financial aid is required to carry out the project;

**THEREFORE, BE IT RESOLVED**, that the City of Gillett has budgeted a sum sufficient to complete the project or acquisition and,

**HEREBY AUTHORIZES**, Chelsea Anderson, City Clerk/Treasurer, to act on behalf of the City of Gillett to:

- Submit an application to the State of Wisconsin Department of Natural Resources for any financial aid that may be available;
- Submit reimbursement claims along with necessary supporting documentation within 6 months of project completion date;
- Submit signed documents; and
- Take necessary action to undertake, direct and complete the approved project.

**BE IT FURTHER RESOLVED** that the City of Gillett will comply with state or federal rules for the programs; may perform force account work; will maintain the completed project in an attractive, inviting and safe manner; will keep the facilities open to the general public during reasonable hours consistent with the type of facility; and will obtain from the State of Wisconsin Department of Natural Resources or the National Park Service approval in writing before any change is made in the use of the project site.

**ADOPTED** this 6<sup>th</sup> day of March 2025.

I hereby certify that the foregoing resolution was duly adopted by the City of Gillett City Council at a legal meeting on March 6, 2025.

\_\_\_\_\_  
Jon Blaskowski, Mayor

\_\_\_\_\_  
Chelsea Anderson, Clerk/Treasurer

**CITY OF GILLETT**  
**150 N. MCKENZIE AVE**  
**GILLETT, WI 54124**

**PROJECT AND LOCATION** – Addition of an inclusive play area, walking trails/paths, ADA restroom, signage, and picnic/seating areas. Improvements to the sports courts.

**PROJECT COST** - \$1,500,000

## Chelsea Anderson

---

**From:** Art Bahr <abahr@msa-ps.com>  
**Sent:** Wednesday, March 5, 2025 9:24 AM  
**To:** Michelle Seefeldt; Monty Brink  
**Cc:** Chelsea Anderson; Jon Blaskowski; gillettshell@centurytel.net  
**Subject:** Request Amendment of County CORP for Gillett project  
**Attachments:** 09443017 Gillett County CORP addition 03052025.docx

Monty,

The City of Gillett respectfully requests an amendment to the 2024 Oconto County CORP. The City is submitting for a Wisconsin Stewardship grant and therefore will need to show that the project is listed in a current CORP. The City does not have a CORP at this time. The application is due May 1<sup>st</sup>. We would need to have it acted on and have a copy of the official minutes prior to grant application submission.

I've attached a project description page formatted similar to the other projects listed in Chapter 6.

Let me know if the above request can be accomplished by required time. If you have any questions, please let me know.

I have copied the Gillett Clerk, Jerry Luther, and the Mayor on this email.

Sincerely,

Art



**Art Bahr** | Senior Community Development Administrator

MSA Professional Services, Inc.

100% Employee Owned

+1 (920) 545-2086, [abahr@msa-ps.com](mailto:abahr@msa-ps.com)



Sign up for our newsletter, [MSA Today](#).



# City of Gillett

## Special Event Permit Application

City of Gillett | 150 N McKenzie Ave | Gillett, Wisconsin 54124  
Phone (920) 855-2255 | Fax (920) 855-6283 |



### \*Special Event Information

Application Fee: \$0.00

Name/Company/Organization Name: Gillett Civic Club

Mailing Address: PO Box 434 Gillett WI

Phone: Ann Henrichs 920 373 3707

Name of Event: 4th of July Celebration

Event Date(s): July 3, 4 2025 Application Date: 1-6-2025

\*Applications must be filed 45 days in advance of the event

Actual Event Hours: July 3rd - July 4th

Date(s) for Prep/Setup: July 2nd - TWP Setup TBD Hours for Prep/Setup: 7-7 - 8-8

Date for Cleanup: July 5th AM Hours for Cleanup: 8-2

Projected Attendance: 75-100 100-125 125-150 150+

Location of Event (street address): Zippel Park - 150 N McKenzie Ave

Is the Event Location: (circle) Private Property   Public Property  Streets or Right-of-Way

Event Includes (circle all that apply)  Temporary Signs  Tents/Temporary Structures  Fireworks

Use of Streets or Right-of-Way  Consumption of Alcohol  Food Preparation  None of the Above

Amplified sound  Inflatables  Grills/Fryer/Cooking Utility

Location: Please Choose

Zippel Park

Honey Park

### \*Terms & Conditions

I hereby agree that as a condition to the issuance of a Special Event Permit, the Producer of the Event shall indemnify and hold the City of Gillett harmless from claims, demand or cause of action which may arise from activities associated with the event.

I hereby solemnly swear, subject to criminal penalties for false swearing, that the statements and answers made by me to the foregoing questions in this application for a Special Event Permit, are true, and no false or fraudulent statement or answer is made herein to procure the granting of such permit.

I hereby certify that the site plan and description provided will be constructed and/or used in accordance with all applicable zoning ordinances and laws governing the City of Gillett, Wisconsin.

I hereby state and understand that should a complaint be filed against the Producer of the Event for violation of any regulation associated with the application for the City of Gillett Special Event Permit, the permit issued for the event will immediately become void and will not reissue for the same location.

The City of Gillett reserves the right to photograph and videotape all events, camps, classes, programs, and facilities for promotional purposes. The participant hereby releases the City from any liability resulting there from. I have received a copy of the Park Reservation Policy and agree to the terms:

Responsible Party Name: \_\_\_\_\_

Responsible Party Signature: \_\_\_\_\_ Date: \_\_\_\_\_

Ann Henrichs

1-6-2025

CITY OF GILLETT

150 N MCKENZIE AVENUE, GILLETT WI 54124

ProCheck Inspections LLC, Bryan Lauritzen • 920-373-7598 • procheckwi@gmail.com

Hours: Monday-Friday 8:00 am - 4:00 pm

Fee:	<b>Uniform Building Permit Application</b>	Application No.
PERMIT REQUESTED: Check All That Apply		Parcel No. <b>231-0422213550</b>
<input checked="" type="checkbox"/> Constr. <input checked="" type="checkbox"/> HVAC <input checked="" type="checkbox"/> Electric <input checked="" type="checkbox"/> Plumb. <input checked="" type="checkbox"/> Erosion Control <input type="checkbox"/> Other:		Phone <b>920-655-3177</b>
Owner Name <b>JIM + NANCY VAN ELZEN</b>	Mailing Address (if other than Site Address) <b>P.O. Box 515 GILLETT, WI 54124-0515</b>	

Site Address <b>125 E. FOURTH STREET - GILLETT</b>	Email <b>JNVANELZEN@GMAIL.COM</b>
---	--------------------------------------

Contractor Name & Type	Lic/Cert #	Exp Date	Mailing Address	Phone & Email
Dwelling Contractor (Constr.) <b>JD BUILDERS OF NE WI, INC.</b>	<b>049700063</b>	<b>5/11/25</b>	<b>2076 W. FRONTIER RD. LITTLE SWAMICO, WI 54141</b>	<b>920-826-7841 JIM@JDBUILDERSOFNEWI.COM</b>
Dwelling Contr. Qualifier (The Dwelling Contr. Qualifier shall be an owner, CEO, COB or employee of the Dwelling Contr.)	<b>110700224</b>	<b>11/29/25</b>	" "	<b>920-371-3141 JIM@JDBUILDERSOFNEWI.COM</b>
HVAC <b>JD HEATING + COOLING, INC.</b>	<b>959676</b>	<b>4/20/26</b>	<b>675 W. FRONTIER ROAD LITTLE SWAMICO, WI 54141</b>	<b>920-737-6631 JHEATING@PHILAND.NET</b>
Electrical Contractor <b>HC ELECTRIC SERVICE</b>	<b>1121306-EC</b>	<b>6/30/25</b>	<b>3765 CHESTER RD - ST L DE PERE, WI 54115</b>	<b>920-655-4012</b>
Electrical Master Electrician <b>CHRISTOPHER VAN DOMMELON</b>	<b>958927-MAE</b>	<b>6/30/26</b>	" "	<b>920-655-4012</b>
Plumbing <b>BOUCHARD PLUMBING</b>	<b>6/6/22-PM</b>	<b>3/31/25</b>	<b>6919 COUNTRY OAKS DR. SOBIESKI, WI 54171</b>	<b>920-655-2455</b>

PROJECT LOCATION INFO.	Lot area <b>8700</b> Sq.ft.	<input type="checkbox"/> One acre or more of soil will be disturbed	City of Gillett	SW 1/4, SW 1/4, of Section <b>22</b> , T <b>28</b> N, R <b>18</b> E/W
County: Oconto			Lot No. <b>2</b>	Block No.

Zoning District(s)	Zoning Permit No.	Setbacks: Front <b>50</b> ft., Rear <b>30</b> ft., Left <b>125</b> ft., Right <b>200</b> ft.
--------------------	-------------------	--

PROJECT	OCCUPANCY	ELECTRIC	HVAC EQUIP	ENERGY SOURCE
<input checked="" type="checkbox"/> New <input type="checkbox"/> Repair <input type="checkbox"/> Alter. <input type="checkbox"/> Raze <input type="checkbox"/> Addition <input type="checkbox"/> Move <input type="checkbox"/> Other: <input type="checkbox"/> Remodel <input type="checkbox"/> Siding <input type="checkbox"/> Roof	<input checked="" type="checkbox"/> Single Fam <input type="checkbox"/> Two Fam <input type="checkbox"/> Garage <input type="checkbox"/> Other:	Entrance Panel Amps: <b>200</b> <input checked="" type="checkbox"/> Underground <input type="checkbox"/> Overhead	<input checked="" type="checkbox"/> Furnace <input type="checkbox"/> Radiant Baseboard <input type="checkbox"/> Heat Pump <input type="checkbox"/> Boiler <input checked="" type="checkbox"/> Central Ac <input type="checkbox"/> Fireplace <input type="checkbox"/> Other:	Fuel Type: <input checked="" type="checkbox"/> Nat Gas <input type="checkbox"/> Electric <input type="checkbox"/> LP <input type="checkbox"/> Oil <input type="checkbox"/> Solid <input type="checkbox"/> Solar Geo Space Htg: <input checked="" type="checkbox"/> Nat Gas <input type="checkbox"/> Electric <input type="checkbox"/> LP <input type="checkbox"/> Oil <input type="checkbox"/> Solid <input type="checkbox"/> Solar Geo Water Htg: <input checked="" type="checkbox"/> Nat Gas <input type="checkbox"/> Electric <input type="checkbox"/> LP <input type="checkbox"/> Oil <input type="checkbox"/> Solid <input type="checkbox"/> Solar Geo
AREA INVOLVED (sq ft) Basement: <b>1297</b> House: <b>1440</b> Garage: <b>1193</b> Deck: Porch: <b>96</b> Other: Totals: <b>4026</b>	<input checked="" type="checkbox"/> Site-Built <input type="checkbox"/> Mfd. Per WI UDC <input type="checkbox"/> Mfd. Per US HUD CONSTRUCTION TYPE <input checked="" type="checkbox"/> 1-Story <input type="checkbox"/> 2-Story <input type="checkbox"/> Other: <input checked="" type="checkbox"/> Basement	<input checked="" type="checkbox"/> Wood Frame <input type="checkbox"/> Steel <input type="checkbox"/> IFC <input type="checkbox"/> Timber/Pole <input type="checkbox"/> Other: USE <input type="checkbox"/> Seasonal <input type="checkbox"/> Other: <input checked="" type="checkbox"/> Perm.	<input checked="" type="checkbox"/> Sewer <input type="checkbox"/> Municipal <input checked="" type="checkbox"/> San. Per # Water <input checked="" type="checkbox"/> Municipal <input type="checkbox"/> On-Site Well	EST. BUILDING COST w/o LAND <b>\$ 440,000<sup>00</sup></b>

PROJECT DESCRIPTION (if not building a NEW home)

---



---



---

APPLICANT SHALL CALL THE INSPECTION DIVISION FOR REQUIRED INSPECTION

APPLICANT (Print: JAMES A. HOPKINS III) (Signature: James A. Hopkins III) DATE: 2/25/25

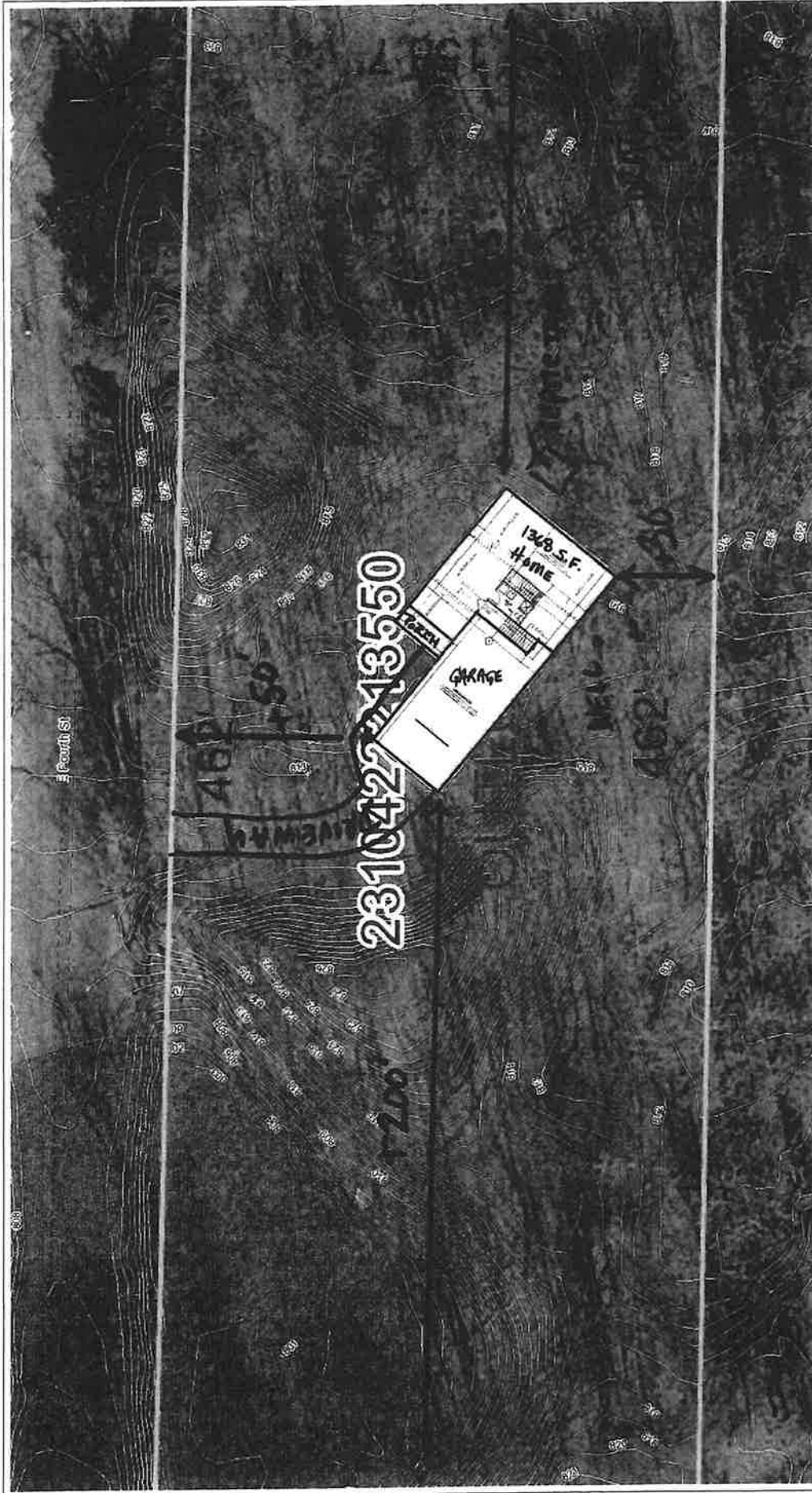

Print Date: 2/19/2025



SCALE: 1" = 29'

# SITE PLAN

**Jim & Nancy Van Elzen**  
125 E Fourth Street, Gillett

Oconto County Land Information Systems makes every effort to produce the most current and accurate information possible. No warranties, expressed or implied, are provided for the data provided, its use, or its interpretation. Oconto County does not guarantee the accuracy of the material contained herein and is not responsible for any misuse or misrepresentation of this information or its derivatives. Oconto County parcel maps are for tax and real property listing purposes only and do NOT represent a survey. The tax parcel maps are compiled from official records, including survey plats and deeds, but only contain the information required for Oconto County business. You should always use the original recorded documents for legal or survey information.

01	PRELIMINARY PLAN	REVISION
02	REVISED	REVISION
03	REVISED	REVISION
04	REVISED	REVISION
05	REVISED	REVISION
06	REVISED	REVISION
07	REVISED	REVISION
08	REVISED	REVISION
09	REVISED	REVISION
10	REVISED	REVISION
11	REVISED	REVISION
12	REVISED	REVISION
13	REVISED	REVISION
14	REVISED	REVISION
15	REVISED	REVISION
16	REVISED	REVISION
17	REVISED	REVISION
18	REVISED	REVISION
19	REVISED	REVISION
20	REVISED	REVISION
21	REVISED	REVISION
22	REVISED	REVISION
23	REVISED	REVISION
24	REVISED	REVISION
25	REVISED	REVISION
26	REVISED	REVISION
27	REVISED	REVISION
28	REVISED	REVISION
29	REVISED	REVISION
30	REVISED	REVISION
31	REVISED	REVISION
32	REVISED	REVISION
33	REVISED	REVISION
34	REVISED	REVISION
35	REVISED	REVISION
36	REVISED	REVISION
37	REVISED	REVISION
38	REVISED	REVISION
39	REVISED	REVISION
40	REVISED	REVISION
41	REVISED	REVISION
42	REVISED	REVISION
43	REVISED	REVISION
44	REVISED	REVISION
45	REVISED	REVISION
46	REVISED	REVISION
47	REVISED	REVISION
48	REVISED	REVISION
49	REVISED	REVISION
50	REVISED	REVISION

**FINAL PLAN**

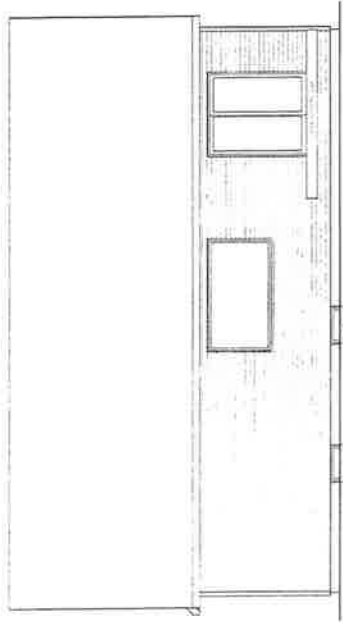

**REAR ELEVATION**  
 1/4" = 1'-0"

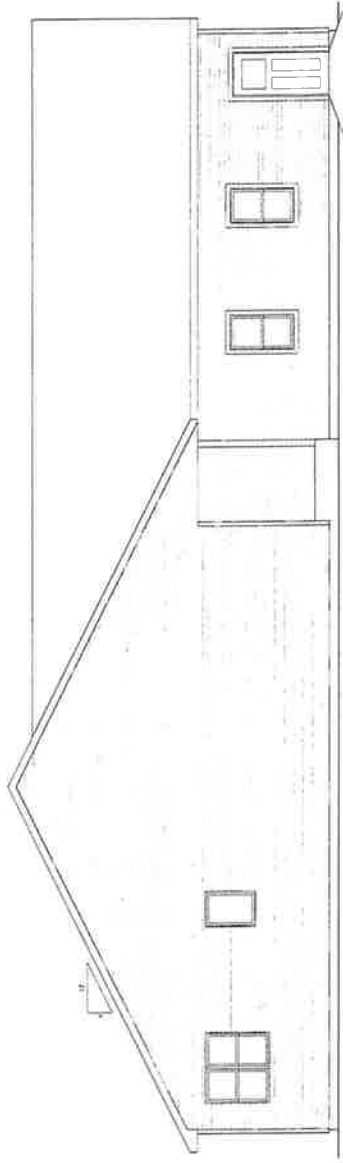

**LEFT ELEVATION**  
 1/4" = 1'-0"

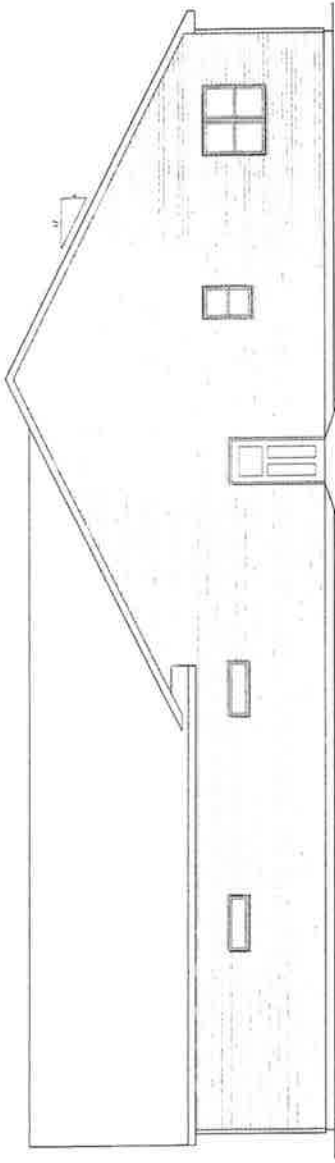

**RIGHT ELEVATION**  
 1/4" = 1'-0"

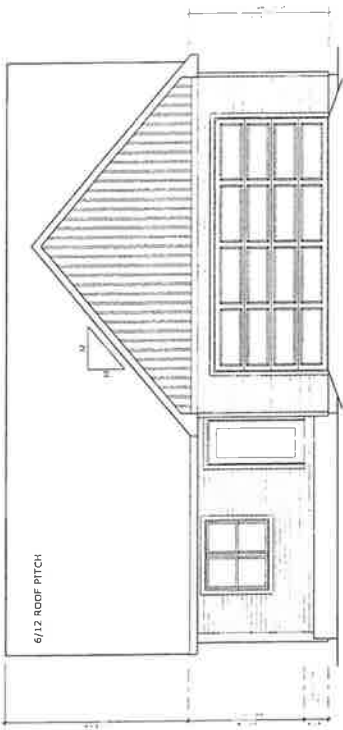

**FRONT ELEVATION**  
 1/4" = 1'-0"

6/12 ROOF PITCH

FIRST FLOOR AREA	1368 SF
<b>TOTAL AREA</b>	<b>1368 SF</b>
GARAGE FLOOR AREA	1493 SF